

2014 ISSUE 1



**THE EXHIBITORS'™**  
**HAND**  
**BOOK**  
**MODULAR DISPLAY SOLUTIONS**



1 | BANNER STANDS | RETRACTABLE

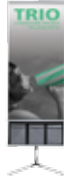

9 | BANNER STANDS | TELESCOPIC



10 | BANNER STANDS | SPRING BACK



14 | BANNER STANDS | AERO



15 | TABLE THROWS & RUNNERS



19 | OUTDOOR DISPLAYS



27 | HOPUP™ TENSION FABRIC DISPLAYS

**SYMBOLS USED IN THE EXHIBITORS' HANDBOOK™:**



product made in the U.S.



economy product



premium product



product can be recycled  
(does not include graphic application)



product comes with a carry bag or case



standard product

COYOTE™ POPUP DISPLAY SYSTEMS | 33



FORMULATE™ TENSION FABRIC SYSTEMS | 38



VECTOR FRAME™ FABRIC DISPLAYS | 83



ORBITAL EXPRESS™ TRUSS | 95



LINEAR™ EXTRUSION DISPLAYS | 113



FOLDING DISPLAY PANELS | 115



ACCENTS & ACCESSORIES | 120



WARRANTY KEY FOR THE EXHIBITORS' HANDBOOK™:



lifetime limited warranty (hardware)



5 year limited warranty (hardware)



1 year limited warranty (hardware)



90 day limited warranty (hardware)



graphics limited 1 year warranty (indoor products)



graphics limited 6 month warranty (outdoor and table throw products)



# FAST.CLEAR.COMMUNICATION. **BANNER STANDS**

Largest selection of banner stand choices and options • Premium, mid-range and economy stands • Retractable, Telescopic and Spring Back options • Great quality • High-end functionality, features and durability • Specifically designed with unique styling points, giving an exceptional appearance • Multiple accessory and light options



### BLADE LITE

23.5" WIDE BLD-LT-600

36" WIDE BLD-LT-920

47.25" WIDE BLD-LT-1200

59" WIDE BLD-LT-1500

- standard height = 83.25"
- four widths to choose from: 23.5", 36", 47.25", 59"
- premium top rail
- weighted base for stability
- adjustable leveling feet
- 4-piece bungee pole



## PREMIUM RETRACTABLE BANNER STANDS



Premium Retractable banner stands provide superior, high-end functionality, features and durability, as well as unique styling points for exceptional appearance. Premium banners include a protective, molded carry bag and feature a lifetime hardware warranty.

BANNER STANDS | RETRACTABLE

PREMIUM



### IMAGINE

31.5" WIDE IMG-800-S

- variable graphic height = 29.5" - 83.35"
- graphic tensioner
- integrated pole storage
- interchangeable graphic cassette
- adjustable feet on base
- telescopic pole
- shown with optional literature pocket accessory (AKIT-1L)



### BARRACUDA

31.5" WIDE silver: BCD-800-S  
black: BCD-800-B

- variable graphic height = 29.5" - 83.35"
- anodized silver or black base options
- graphic tensioner
- integrated pole storage
- adjustable feet on base
- telescopic pole
- shown with optional literature pocket and tabletop accessory (AKIT-1S1L)



### ADVANCE

31.5" WIDE ADV-800-S

- variable graphic height = 29.5" - 83.35"
- double-sided
- graphic tensioner
- integrated pole storage
- interchangeable graphic cassette
- adjustable feet on base
- telescopic pole
- shown with optional light Lumina 2 (LUM-2-1)



### EXCALIBUR

31.5" WIDE EXC-800-S

- variable graphic height = 29.5" - 83.35"
- double-sided
- anodized silver base
- graphic tensioner
- integrated pole storage
- adjustable feet on base
- telescopic pole
- shown with optional tabletop accessory (AKIT-1S)





## STANDARD RETRACTABLE BANNER STANDS

Standard Retractable banner stands incorporate customary features designed to provide everyday reliability, durability and ease of use. Standard banners include a mid-range canvas carry bag and typically feature a five-year to lifetime hardware warranty.



### ORIENT 1

**31.5" WIDE** silver: ONT-800-S-3  
black: ONT-800-B-3

**35.5" WIDE** silver: ONT-920-S-3  
black: ONT-920-B-3

**39.25" WIDE** silver: ONT-1000-S-3  
black: ONT-1000-B-3

- standard graphic height = 83.25"
- anodized silver or black base options
- molded end caps
- adjustable feet on base
- 3-piece bungee pole



### ORIENT 2

**31.5" WIDE** ONT-800-DBL-S-3

**35.5" WIDE** ONT-920-DBL-S-3

- standard graphic height = 83.25"
- double-sided
- anodized silver base
- molded end caps
- adjustable feet on base
- 3-piece bungee pole



### PACIFIC

**31.5" WIDE** PAC-800-S-2

**35.5" WIDE** PAC-920-S-2

**39.25" WIDE** PAC-1000-S-2

- standard graphic height = 83.75"
- anodized silver base
- molded end caps
- swivel-out foot
- 3-piece bungee pole



### CONTENDER

**23.5" WIDE** silver: CN-24-S  
black: CN-24-B

**29.5" WIDE** silver: CN-30-S  
black: CN-30-B

**35.5" WIDE** silver: CN-36-S  
black: CN-36-B

**47.5" WIDE** black: CN-48-B

- standard graphic height = 77.5"
- swivel-out foot
- silver or black base options
- laser cut steel ends & 3-piece part pole



# STANDARD RETRACTABLE BANNER STANDS



Standard Retractable banner stands incorporate customary features designed to provide everyday reliability, durability and ease of use. Standard banners include a mid-range canvas carry bag and typically feature a five-year to lifetime hardware warranty.



## ELEVATE

33.25" WIDE ELEVATE

- variable graphic height = 37.75" - 95.25"
- roller access via flip-top lid and removable graphic roller
- black aluminum body with chrome end caps
- telescopic pole (4 segments)



## BLADE LX

33.5" WIDE BLD-LX-GRY

- standard graphic height = 83.25"
- anodized gunmetal base
- removable graphic roller
- graphic slider
- adjustable feet on base
- premium top rail
- 3-piece bungee pole



## CRESCENT

33.25" WIDE CRESCENT

**NEW**

- standard graphic height = 78.25"
- snap top graphic rail
- silver base with black end caps
- 3-piece bungee pole



## BLOK

33.5" WIDE BLOK-850

- standard graphic height = 79.25"
- snap top graphic rail
- black base with chrome end caps
- 3-piece bungee pole







## ECONOMY RETRACTABLE BANNER STANDS

Economy Retractable banner stands incorporate basic design features, functionality and reliability. Economy banners include a basic carry bag and feature a 90-day hardware warranty.



### START

31.25" WIDE STRT-800

- standard graphic height = 79.25"
- snap top graphic rail
- swivel foot
- anodized silver base
- 3-piece bungee pole



### FREEDOM

31.5" WIDE FRDM-800

- standard graphic height = 79.25"
- snap top graphic rail
- new chrome end caps
- 3-piece bungee pole



### DRAGON FLY

33.25" WIDE DRAGON FLY **NEW**

- standard graphic height = 78.25"
- double-sided
- snap top graphic rail
- 3-piece bungee pole



### ECO

36" WIDE ECO **NEW**

- standard graphic height = 79.375"
- velcro graphic application
- snap top graphic rail
- 3-piece bungee pole



# ECONOMY RETRACTABLE BANNER STANDS

Economy Retractable banner stands incorporate basic design features, functionality and reliability. Economy banners include a basic carry bag and feature a 90-day hardware warranty.



BANNER STANDS | RETRACTABLE



shown at maximum and minimum heights



## GIANT MOSQUITO

**35.5" WIDE** MSQT-GIANT-920-S

- variable graphic height = 68" - 122"
- over 10' tall
- anodized silver base
- swivel-out feet
- snap top graphic rail
- adjustable telescopic pole
- heavy duty, weighted stand

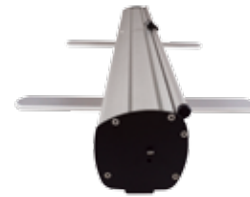

ECONOMY

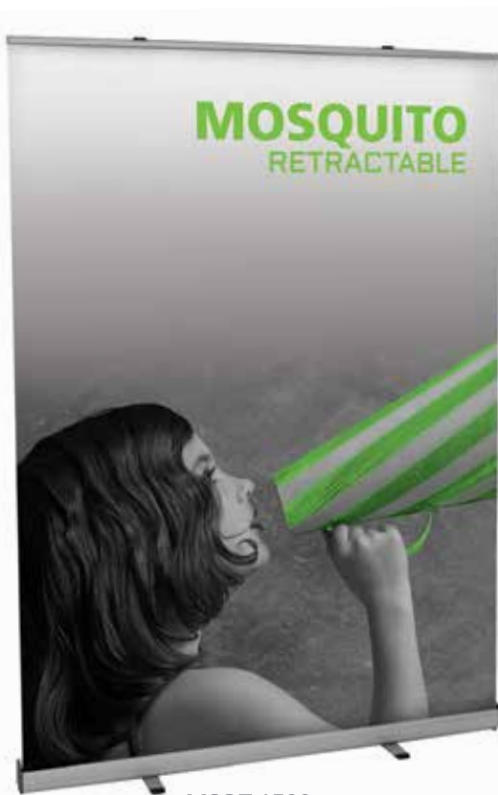

MSQT-1500



MSQT-1200



MSQT-800

## MOSQUITO

**31.5" WIDE** silver: MSQT-800  
black: MSQT-800-B

**47.25" WIDE** silver: MSQT-1200

**59" WIDE** silver: MSQT-1500

- standard graphic height = 78.5"
- anodized silver or black base options (800mm only)
- swivel-out feet & snap top graphic rail
- 800mm unit is supplied with one bungee pole per unit, 1200mm and 1500mm come with two bungee poles per unit





## ECONOMY RETRACTABLE BANNER STANDS

Economy Retractable banner stands incorporate basic design features, functionality and reliability. Economy banners include a basic carry bag and feature a 90-day hardware warranty.

### QUICKWALL

31.5" WIDE silver: QWK-S  
black: QWK-B

- standard graphic height = 78.5"
- approx. overall width = 97"
- graphic width = 31.5"
- anodized silver or black base options
- kit includes 3 Mosquito 800 banner stands and 1 OCB banner stand case
- snap top graphic rail



### QUICKSTAND

31.5" WIDE silver: QWK-STND-S  
black: QWK-STND-B

- standard graphic height = 78.5"
- anodized silver or black base options
- kit includes 1 Mosquito 800 banner stand, 1 OCB banner stand case, and 1 Lumina 5 banner stand light
- swivel-out foot
- snap top graphic rail
- 3-piece bungee pole



# STANDARD TELESCOPIC BANNER STANDS



Standard Telescopic banner stands incorporate customary features designed to provide everyday reliability, durability and ease of use. Standard banners include a mid-range canvas carry bag and typically feature a one-year hardware warranty.

BANNER STANDS | TELESCOPIC

STANDARD



## PEGASUS

52.5" - 95" WIDE silver: PGSUS-S  
black: PGSUS-B

- variable graphic height = 36" - 96"
- single or double-sided graphics
- allows for custom size graphics
- easy to store
- steel feet for stability
- telescopic pole for adjustable graphic width and height



## UNO

31.5" WIDE UN-1-ST

35.5" WIDE UN-1-MG

48" WIDE UN-1-MO



- variable graphic height = 35" - 85.5"
- powder coated black weighted base



## TRIO

31.5" WIDE TRIO



- variable graphic height = 28.75" - 84"
- tri-pod banner stand
- hardware included supports single and double-sided graphic
- stable, anodized aluminum
- telescopic pole for adjustable graphic height
- quick & easy to set up



Includes hardware for double-sided graphics



## TRIO LITERATURE POCKET

31.5" WIDE TRIO-LP



- graphic height with literature pocket = 63.5"
- 3 pocket literature dispenser to attach to a TRIO banner stand



# STANDARD SPRING BACK BANNER STANDS

Standard Spring Back banner stands incorporate customary features designed to provide everyday reliability, durability and ease of use. Standard banners include a mid-range canvas carry bag and typically feature a one-year hardware warranty.



## LIGHTNING

31" WIDE LTNG

- standard graphic height = 77"
- snap-lock graphic rails
- 3-piece bungee pole



# ECONOMY SPRING BACK BANNER STANDS



Economy Spring Back banner stands incorporate basic design features, functionality and reliability. Economy banners include a basic carry bag and feature a 90-day hardware warranty.



## SPRING 1-1

23.5" WIDE SB-1-1

- graphic height = 59" or 78"



## SPRING 1-2

26.5" WIDE SB-1-2

- graphic height = 59" or 78"



## SPRING 1-3

35.125" WIDE SB-1-3

- graphic height = 59" or 78"



## SPRING 3

27.5" WIDE SB-3

- standard graphic height = 70.75"  
 - #3 grommets in corners  
 - single or double-sided





# ECONOMY SPRING BACK BANNER STANDS

Economy Spring Back banner stands incorporate basic design features, functionality and reliability. Economy banners include a basic carry bag and feature a 90-day hardware warranty.



### SPRING 4

27" WIDE SB-4

- standard graphic height = 62.25"
- #3 grommets in corners



### SPRING 6

24.5" WIDE SB-6

- standard graphic height = 63"
- #3 grommets in corners



### SPRING 7

29.5" WIDE SB-7

- variable graphic height = 61.5" - 69"
- #3 grommets in corners



### VIEW SET-UP VIDEOS OF EXHIBITORS' HANDBOOK PRODUCTS



## CAFÉ BARRIER

CB-K-1500  
CB-EXT-K-1500



- indoor/outdoor modular display system
- stylish way to define areas or dictate traffic flow in or outside restaurants, bars, retail establishments, airports, museums, casinos and at tradeshows
- visual graphic area = approx. 53.25" w x 30.5" h
- heavy-duty stainless steel posts, base and 59" w rails
- unit kit, extension kit and individual components available



### Café Barrier Kit:

CB-K-1500

- comes with top and bottom poles – 59" w,  
2 uprights & 2 bases

### Café Barrier Extension Kit:

CB-EXT-K-1500

- comes with top and bottom poles – 59" w,  
1 upright & 1 base



use as outdoor café barriers



use for crowd control



use to guide traffic



# AERO



- NEW and IMPROVED
- indoor modular display system
- standard width = 47"
- 12 graphic height options
- available as a kit and "a la carte" to create more combinations

### Aero Basic Kit:

AERO2-1200-BASIC

- comes with 3 cassettes and 4 uprights with bases

### Aero Complete Kit:

AERO2-1200-KIT

- comes with 3 cassettes, 4 uprights with bases and 3 LUM-LED-ORL-B lights

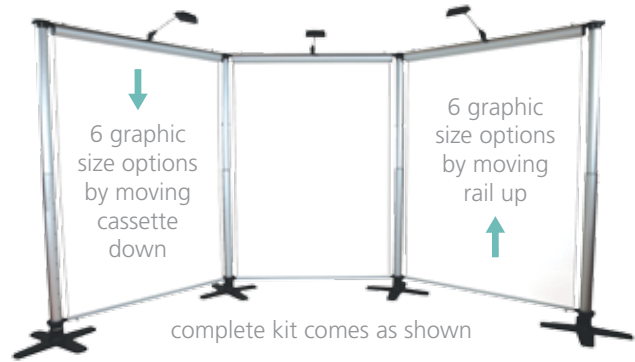

lights can now be placed anywhere on the cassette



### 12 GRAPHIC HEIGHT OPTIONS AVAILABLE

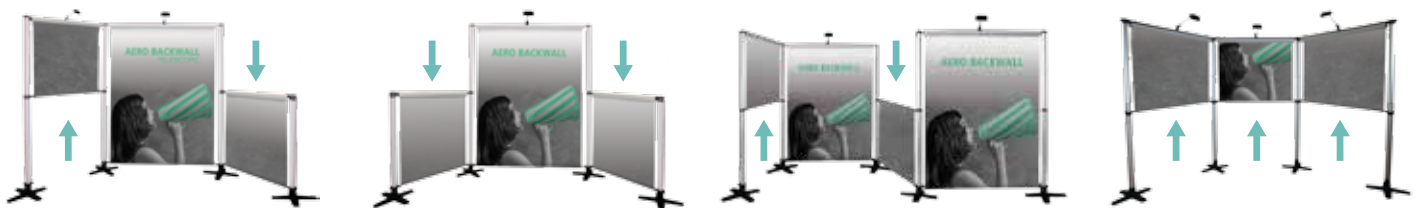

configure height by moving top cassette downwards

configure height by moving bottom rail upwards



# MEET.AND.GREET. TABLE THROWS & RUNNERS

One-stop-shop for the fastest table throws and runners • Can be used in many ways; perfect to display your messaging in any tradeshow or event – indoor or outdoor • Printed, imprinted, convertible, stretch and fitted options to choose from • Sizes of 4', 6', 8', full and economy • Choose from 11 fabric colors and 21 vinyl colors

**PRINTED TABLE THROW**

- 4' full: TBL-T-4-F
- 4' economy: TBL-T-4-E
- 6' full: TBL-T-6-F
- 6' economy: TBL-T-6-E
- 8' full: TBL-T-8-F
- 8' economy: TBL-T-8-E

- complete your presentation with a premium printed table throw
- lends a polished appearance to any display
- maximize your advertising with additional space to display your message



shown with Horizon Standard tabletop folding panel display (page 119)



4' table throws available for smaller tables

carry bag available  
(6 table throws)  
TBL-THRW-BG



carry bag available  
(4 table throws)  
TBL-THRW-BG2



shown as 8' convertible table throw



shown as 6' converted table throw

**CONVERTIBLE TABLE THROW**

- convertible full: TBL-T-FC
- convertible economy: TBL-T-EC

- printed throw converts quickly and easily to fit both a 6' and 8' table
- Velcro tabs make conversion simple



All table throws and runners come with a graphic limited warranty of 6 months and are made in the USA

**TABLE RUNNERS**

- 24" full: TBL-R-24-F
- 24" economy: TBL-R-24-E
- 30" full: TBL-R-30-F
- 30" economy: TBL-R-30-E
- 60" full: TBL-R-60-F
- 60" economy: TBL-R-60-E

- accent your solid colored table throw with a full color printed runner
- available in three widths



**FITTED TABLE THROW**

- 6' full: TBL-FT-6-F
- 8' full: TBL-FT-8-F

- form fitted to fit 6' & 8' tabletops
- optional carry bag available
- fitted fabric dye-sublimated printed table throw lends a polished look to any display



**STRETCH TABLE THROW**

- 6' full: TBL-SW-6-F
- 8' full: TBL-SW-8-F

- tailored to fit 6' & 8' tables top to bottom
- optional carry bag available
- stretch fabric dye-sublimated printed table throw lends a stylish look to any display



All table throws and runners come with a graphic limited warranty of 6 months and are made in the USA

## IMPRINTED TABLE THROW

- 6' full
- 6' economy
- 8' full
- 8' economy

- 11 standard table throw colors
- maximum logo size = 60" w x 21.5" h (see template for details)
- must be simple vector artwork, no complex logos or gradients
- maximum two vinyl colors per logo imprint
- referenced Pantone colors are not exact
- vinyl is heat transferred



full table throw shown in purple fabric with white and sky blue imprinted vinyl



economy table throw leaves back of table exposed for easy access to storage

### FULL TABLE THROW

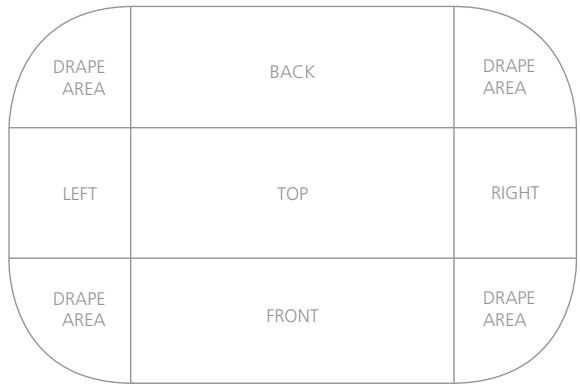

### ECONOMY TABLE THROW

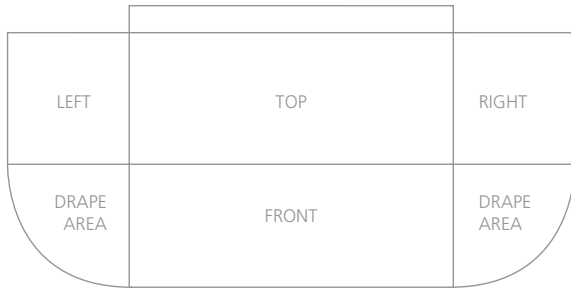

### FABRIC COLORS

red Pantone® 201C	royal blue Pantone® 661C	purple Pantone® Violet C	yellow Pantone® 1235C
beige Pantone® 728C	burgundy Pantone® 504C	gray Pantone® 422C	hunter green Pantone® 350C
navy Pantone® 282C	black	white	

### VINYL COLORS

black	white	blue Pantone® 293C	hot pink Pantone® Process Magenta C	royal purple Pantone® 2755C	red Pantone® 200C	vegas gold Pantone® 467C
kelly green Pantone® 342C	sky blue Pantone® 283C	lemon yellow Pantone® 101C	medium yellow Pantone® 123C	burnt orange Pantone® 167C	orange Pantone® 021C	gray Pantone® Cool Gray 9C
navy Pantone® 2766C	apple green Pantone® 368C	forest green Pantone® 350C	vanilla cream Pantone® 7499C	sapphire blue Pantone® 2925C	brown Pantone® 1545C	teal Pantone® 315C



All table throws and runners come with a graphic limited warranty of 6 months and are made in the USA



# CAPTURE.YOUR.ATTENTION. OUTDOOR DISPLAYS

One-stop-shop for all your outdoor signage needs • The Zoom™ line of outdoor flags span heights of 8' to over 16' • Great for outdoor sporting events and arenas, concerts, festivals or to draw attention to any storefront • Strong, solid, stable, wind-resistant, durable • Graphics are long-lasting and can endure exposure to outdoor elements

## ZOOM™ TENT

hardware only kit: TNT-3MX3M-FRM-HEX  
kit with canopy: TNT-3MX3M-HEX-(COLOR)  
canopy only: TNT-CAN-(COLOR)  
full wall kits: TNT-FLL-WLL-(COLOR)  
half wall kits: TNT-HLF-K-(COLOR)



- opens to base size of 9.6' x 9.6'; coverage area shades 5 people comfortably
- rust-resistant aluminum extrusion frame is completely self-contained with no loose parts
- canopy offered in 5 standard colors (black, blue, grey, white and red) with heat-press logos and/or vinyl lettering; can also be custom printed
- polyester canopies and sidewalls are water and UV-resistant, providing the ultimate protection from the sun
- hardware only kit includes frame, stakes, guy lines and rolling carrying bag
- canopy kits include canopy (standard colors or custom printed), hardware frame, stakes, guy lines and rolling carrying bag
- sidewalls and rail skirts offered in standard colors and custom prints; sold separately
- folds compactly into portable, rolling carry bag
- optional hard shell OCE expandable case available as an upgrade

comes with  
easy compact  
roller bag



OUTDOOR DISPLAYS

digitally printed  
canopies, sidewalls  
and backwalls  
available



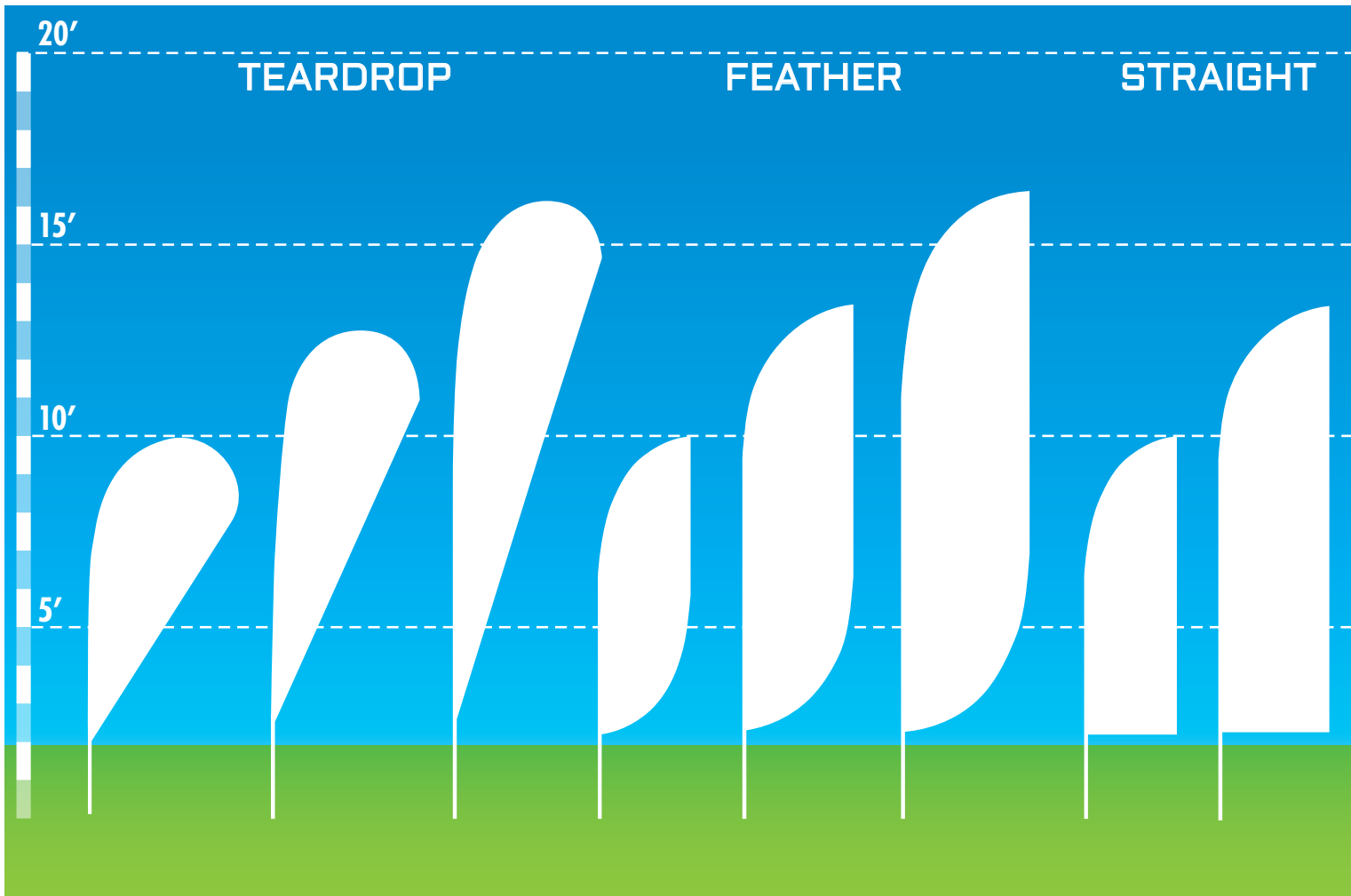

### ZOOM™ FLAGS

- can be used indoors or outdoors
- graphic rotates in wind
- water fillable donut adds stability to quad leg (optional upgrade)
- graphic printed on flag material
- double-sided graphic available
- floor base & ground stake included



shown with X-base and optional upgrade donut water fillable base ZOOM-INDOOR-BASE-SET



All Outdoor products have a one year limited hardware warranty and are eco-friendly.



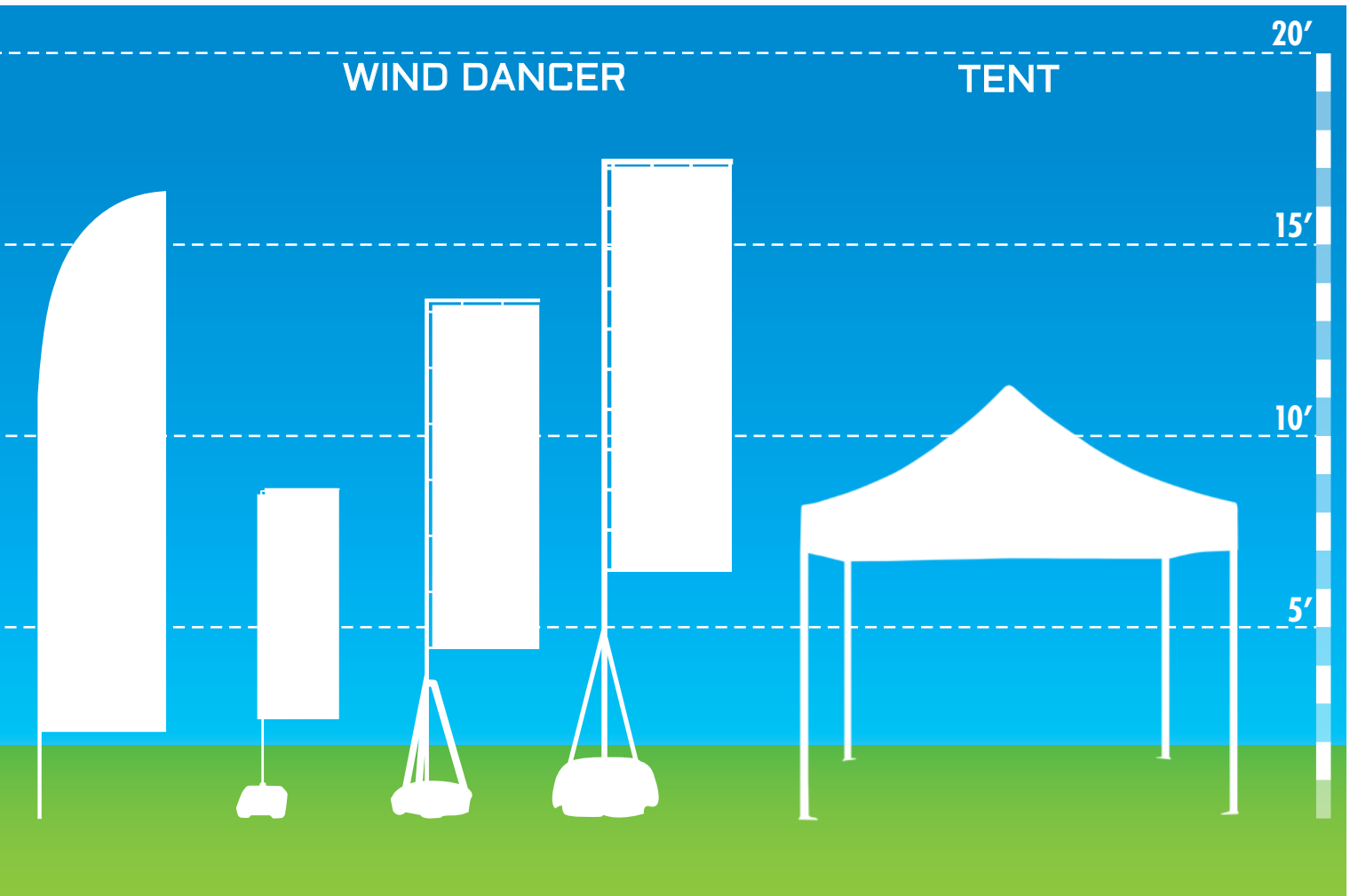

ZOOM™ BASE OPTIONS

STAND ALONE BASES



atlas base  
(ATLAS-ZOOM-PIN)



donut base  
(ZOOM-INDOOR-BASE-SET)



auger base  
(ZOOM-AUG)



ground stake  
(included)



drive-over base  
(ZOOM-VEHICLE)



All Outdoor products have a one year limited hardware warranty and are eco-friendly.

# OUTDOOR SIGNAGE

Outdoor signage, flags and displays are great for outdoor sporting events and arenas, concerts, festivals or to draw attention to any storefront. Outdoor display products are strong, solid, stable, wind-resistant and durable. Graphics are long-lasting and can endure exposure to outdoor elements.



**WIND DANCER MINI**  
WIND-MIN

- adjustable graphic height = up to 6'
- economy outdoor flag
- plastic pole, easy push-fit assembly
- hollow plastic base can be filled with water or sand
- double-sided graphic available



**WIND DANCER LT**  
WIND-LT

- adjustable graphic height = up to 8'8"
- hollow base can be filled with either water or sand as weighing agent
- double-sided graphic available
- optional carry bag



**WIND DANCER**  
WIND-MX

- adjustable graphic height = up to 12'
- flag is approximately 43" wide
- hollow base can be filled with either water or sand as weighing agent
- double-sided graphic available
- optional carry bag



**PROMOTIONAL UMBRELLA**



- printed promotional umbrella – 8’11” dia. canopy
- canopy also available in off-white, green and burgundy stock colors
- can be used for commercial or residential use
- steel poles and arms are white
- overall height with umbrella = 94”
- carry bag included



off-white hunter green burgundy



TOP VIEW

\*base sold separately



**CAFÉ BARRIER**

CB-K-1500  
CB-EXT-K-1500



- indoor/outdoor modular display system
- visual graphic area = approx. 53.25”w x 30.5”h
- heavy-duty stainless steel posts, base and 59”w rails
- unit kit, extension kit and individual component options available



use as outdoor café barriers



use for crowd control

**PARKWAY**

single span: PKWY-S-SPN-3  
double span: PKWY-D-SPN-3

- single span = 32”l x 60”h
- double span = 67”l x 60”h
- withstands winds up to 38MPH
- single or double span street pole banner



## OUTDOOR SIGNAGE

Outdoor signage, flags and displays are great for outdoor sporting events and arenas, concerts, festivals or to draw attention to any storefront. Outdoor display products are strong, solid, stable, wind-resistant and durable. Graphics are long-lasting and can endure exposure to outdoor elements.



### SPRING 5

SB-5

- standard graphic height = 70.75"
- 31.5" wide
- indoor or outdoor use
- single or double-sided
- hollow base can be filled with either water or sand as weighing agent
- easy grommet graphic attachment
- tension pole system



### BLIZZARD

BLZD

- max width x min height: 40" w x 49.5" h
- min width x max height: 23.5" w x 80" h
- max width x max height: 40" w x 74.5" h
- min width x min height: 23.5" w x 49.5" h
- outdoor banner stand
- hollow base can be filled with either water or sand as weighing agent
- easy grommet graphic attachment



### THUNDER

NEW

- visual graphic area = approx. 33.5" w x 79.7" h
- double-sided outdoor retractable banner stand
- large twist-lock feet
- stakes included to secure to ground
- snap-top graphic rail
- 3-piece bungee pole

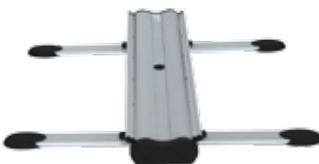

### MONSOON

MONSN-2

- visual graphic area = approx. 92.125" w x 32" h
- semi-portable single or double-sided billboard
- easy grommet graphic attachment
- includes ground stakes & bungee rope





## OUTDOOR SIGNAGE

Outdoor signage, flags and displays are great for outdoor sporting events and arenas, concerts, festivals or to draw attention to any storefront. Outdoor display products are strong, solid, stable, wind-resistant and durable. Graphics are long-lasting and can endure exposure to outdoor elements.

### NAVIGATOR **NEW** NAVIGATOR

- visual graphic area = approx. 12.8" w x 14.8" h
- free-standing outdoor portable sign stand
- stands 47" h
- hollow plastic base can be filled with water or sand
- easy three-piece assembly
- packs flat into box



### WHIRLWIND WHRL-WND-1

- 31.1" w x 45.7" h x 19.7" d
- front-loading snap frames constructed from aluminum & powder-coated steel
- single or double-sided
- includes clear lens cover
- dual-spring design flexes to withstand wind gusts
- compact durable base can be filled with water or sand for extra stability
- integrated wheel set



### BRUTE BRUTE

- comes with set of two; holds large rigid graphics
- secure grip allows for use outdoors in the elements as well as inside
- quick set-up, easy storage
- fill with water or sand, must empty 100% after use



contoured base sits stable on uneven terrain

recommended width:  
1 Brute per 4' of signage

### ATLAS **NEW** ATLAS

- outdoor sign or Zoom flag holder
- use as many as you need to hold a large rigid graphic .4"-.5" thick
- securely holds a Zoom 3, 4 or 5 outdoor flag pole with Zoom attachment (optional upgrade)
- quick set-up, easy storage
- hollow plastic base can be filled with water or sand



ATLAS-ZOOM-PIN

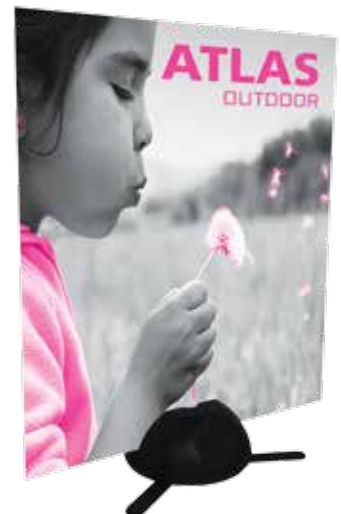



# FAST.DYNAMIC.FABRIC. **HOPUP™ TENSION FABRIC**

Combining style and speed, the intergrated fabric graphic makes the Hopup™ the fastest display on the market • The Hopup is one of the most dynamic and popular large format graphic displays due to its maximum impact with minimal effort • Lightweight and highly portable • Easy to set up and packs away as fast as it sets up



# HOPUP™ BACKWALLS

The Hopup™ is one of the most dynamic and popular large format graphic displays due to its maximum impact with minimal effort. Hopup Tension Fabric Displays come in a variety of sizes and are offered in straight and curved frames. Hopups are lightweight and highly portable and they pack away as easy as they set up! LED lighting makes the Hopup glow and stand out even more.



interior lights are attached with velcro to back fabric panel

## BACKLIT HOPUP™

- lightweight, heavy duty silver frame
- supports an integrated full fitted fabric graphic mural with end caps only
- available in 5', 7 ½' or 10' sizes (curved only)
- LED lights include one year limited warranty
- comes in an OCP molded case



HOP-2X2FGE-C



HOP-3X3FGE-C

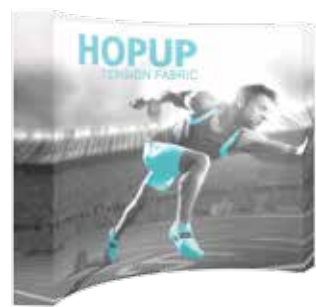

HOP-4X3FGE-C

# STRAIGHT HOPUP™ CONFIGURATIONS



2½' tabletop  
footprint dimensions:  
31" w x 31" h x 12.25" d  
HOP-1X1FG-S



5' tabletop  
footprint dimensions:  
60.5" w x 31" h x 12.25" d  
HOP-2X1FG-S



5' tabletop  
footprint dimensions:  
60.5" w x 60.5" h x 12.25" d  
HOP-2X2FG-S



7½' tabletop  
footprint dimensions:  
89.5" w x 60.5" h x 12.25" d  
HOP-3X2FG-S



2½' full height standard display  
footprint dimensions:  
31" w x 89.5" h x 29" d  
HOP-1X3FG-S



5' full height standard display  
footprint dimensions:  
60.5" w x 90" h x 29" d  
HOP-2X3FG-S

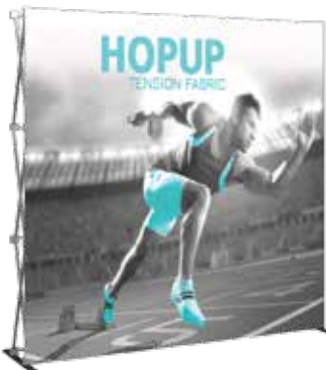

7½' full height standard display  
footprint dimensions:  
89.5" w x 90" h x 29" d  
HOP-3X3FG-S

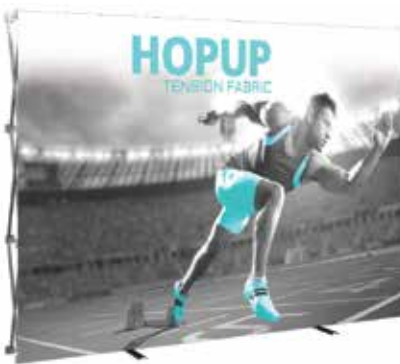

10' full height standard display  
footprint dimensions:  
119" w x 90" h x 29" d  
HOP-4X3FG-S



12¼' full height standard display  
footprint dimensions:  
147.25" w x 90" h x 29" d  
HOP-5X3FG-S

## HOPUP™ COUNTER HOP-CT-2

- NEW and IMPROVED collapsible display counter
- taller and easier to assemble
- includes clear internal shelf
- 41.75" w x 39.69" h x 14.25" d
- top available in four laminate finish options (page 127)

**NEW**



All Hopup frames are eco-friendly, come with a rolling carry case, and have a limited lifetime warranty.



# CURVED HOPUP™ CONFIGURATIONS



5½' tabletop  
footprint dimensions:  
64" w x 31" h x 12.25" d  
HOP-2X1FG-C



5½' tabletop  
footprint dimensions:  
64" w x 60.5" h x 12.25" d  
HOP-2X2FG-C



7½' tabletop  
footprint dimensions:  
92" w x 60.5" h x 12.25" d  
HOP-3X2FG-C



5½' full height standard display  
footprint dimensions:  
64" w x 89.5" h x 12.25" d  
HOP-2X3FG-C



7½' full height standard display  
footprint dimensions:  
92" w x 89.5" h x 12.25" d  
HOP-3X3FG-C



10' full height standard display  
footprint dimensions:  
116.25" w x 89.5" h x 12.25" d  
HOP-4X3FG-C



11½' full height standard display  
footprint dimensions:  
136.5" w x 89.5" h x 12.25" d  
HOP-5X3FG-C

fits in an OC-HOP  
and an OCP wheeled  
molded storage case  
(page 138)



all sizes available  
with or without  
endcaps



All Hopup frames are eco-friendly, come with a rolling carry case, and have a limited lifetime warranty.

# HOPUP™ BACKWALL DIMENSIONS COMPLETE SYSTEMS WITH FRAMES



The Hopup™ is one of the most dynamic and popular large format graphic displays due to its maximum impact with minimal effort. Hopup Backwall Dimensions add style, flare and function to any 7 ½' or 10' Hopup straight display. Easily accessorize your Hopup with monitor mounts, counters, tables, and more messaging real estate. Purchase as a complete kit or as an accessory for your existing straight Hopup. Dimensional elements can be placed in the middle, left or right sides of the display.



## DIMENSION KIT 01

HOP-DIM01-3x3FG-S

- 7 ½' full height straight backwall
- 2 stand-off rigid graphic accents with literature holders
- monitor\* mount supports 23" monitor, max weight = 30 lbs
- 2 Lumina 200 lights



## DIMENSION KIT 02

HOP-DIM02-3x3FG-S

- 7 ½' full height straight backwall
- stand-off counter supports max 25 lbs
- counter features graphic and literature holder
- monitor\* mount supports 23" monitor, max weight = 30 lbs
- 2 Lumina 200 lights



## DIMENSION KIT 03

HOP-DIM03-4x3FGE-S

- 10' full height straight backwall
- accessory counter features:
  - monitor\* mount supports 42" monitor, max weight = 50 lbs
  - counter top holding max weight of 35 lbs
  - printed fabric graphic and literature holder
- 2 Lumina 200 lights



## DIMENSION KIT 04

HOP-DIM04-4x3FGE-S

- 10' full height straight backwall
- standoff counter features:
  - fabric graphic messaging area (top)
  - printed fabric graphic (bottom)
  - counter top holding max weight of 35 lbs
- 2 Lumina 200 lights

Hopup Dimensions counter tops are available in your choice of four thermoform finishes

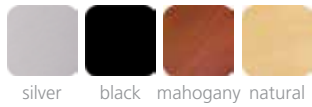

silver black mahogany natural

## HOPUP™ BACKWALL DIMENSIONS ACCESSORY KITS

The Hopup™ is one of the most dynamic and popular large format graphic displays due to its maximum impact with minimal effort. Hopup Backwall Dimensions add style, flare and function to any 7 ½' or 10' Hopup straight display. Easily accessorize your Hopup with monitor mounts, counters, tables, and more messaging real estate. Purchase as a complete kit or as an accessory for your existing straight Hopup. Dimensional elements can be placed in the middle, left or right sides of the display.



**ACCESSORY 01**  
HOP-DIM01

- 2 stand-off rigid graphic accents with literature holders
- monitor\* mount supports 23" monitor, max weight = 30 lbs



**ACCESSORY 02**  
HOP-DIM02

- stand-off counter supports max 25 lbs
- counter fabric graphic and literature holder
- monitor\* mount supports 23" monitor, max weight = 30 lbs



**ACCESSORY 03**  
HOP-DIM03

- accessory counter features:
  - monitor\* mount supports 42" monitor, max weight = 50 lbs
  - counter top holding max weight of 35 lbs
  - printed fabric graphic and literature holder

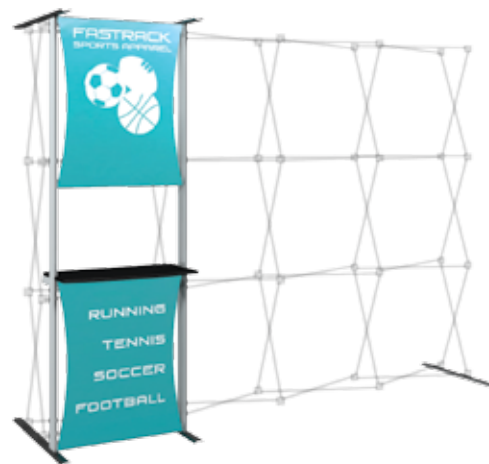

**ACCESSORY 04**  
HOP-DIM04

- stand-off counter features:
  - fabric graphic messaging area (top)
  - printed fabric graphic (bottom)
  - counter top holding max weight of 35 lbs



# RELIABLE.PORTABLE.ESSENTIAL. **POPOP DISPLAY SYSTEMS**

The Coyote™ popup display system combines reliability, portability and style • State-of-the-art rare earth neo magnets on individual channel bars make Coyotes fast and easy to popup and breakdown, especially when compared to complicated “snap in” channel bars and fragile locking style systems • All Coyote displays are offered in curved or straight systems, single or double sided • Option of combining either captivating graphic mural panels or versatile Velcro-friendly fabric panels



# COYOTE™ POPUP DISPLAY SYSTEMS

This fully magnetic popup display system provides a graphic or velcro receptive fabric backwall. Coyote™ popup displays are portable, versatile, durable and easy. The Coyote line features a plethora of accessory options to add such as shelves, monitor mounts and case-to-counter conversion kits and graphics.

POPOP DISPLAY SYSTEMS



## FABRIC CHOICES

All Coyote popup display systems are available with printed graphic murals or "velcro-friendly" fabric panels of your choice. Actual fabric color may vary slightly.

regal - smooth exhibit & display fabric



premier - ribbed exhibit & display fabric





4' tabletop  
footprint dimensions:  
45.5" w x 30.63" h x 12.5" d  
COY-KKG-1X1-C



6' tabletop  
footprint dimensions:  
73" w x 30.63" h x 19.25" d  
COY-KKG-2X1-C



6' tabletop  
footprint dimensions:  
73" w x 59.38" h x 19.25" d  
COY-KKG-2X2-C



8' tabletop  
footprint dimensions:  
97.25" w x 59.38" h x 25" d  
COY-KKG-3X2-C

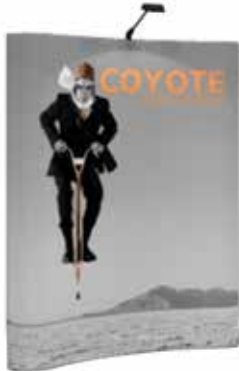

6' full height  
slim-line display system  
footprint dimensions:  
69.3" w x 87.56" h x 19.25" d  
COY-KKG-2X3-C



8' full height  
standard display system  
footprint dimensions:  
97.25" w x 87.56" h x 25" d  
COY-KKG-3X3-C



10' full height  
standard display system  
footprint dimensions:  
118" w x 87.56" h x 36.5" d  
COY-KKG-4X3-C



8' serpentine  
full height display system  
footprint dimensions:  
97.86" w x 87.56" h x 19.5" d  
COY-KKG-ST-8



11' serpentine  
full height display system  
footprint dimensions:  
129.5" w x 87.56" h x 19.5" d  
COY-KKG-ST-10



11' standard horseshoe  
full exhibit system  
footprint dimensions:  
125.2" w x 87.56" h x 54.3" d  
COY-KKG-HS



20' deluxe horseshoe  
full exhibit system  
footprint dimensions:  
193.5" w x 87.56" h x 59.5" d  
COY-KKG-DHS



20' gullwing full trade show  
exhibit system  
footprint dimensions:  
231" w x 87.56" h x 41" d  
COY-KKG-GW



20' serpentine full trade show  
exhibit system  
footprint dimensions:  
217.75" w x 87.56" h x 60.5" d  
COY-KKG-20



All Coyotes come with a limited lifetime hardware warranty. Kits shown come with lights featured.

## OCP CASE TO COUNTER CONVERSION



### OCP

- new premium latches for maximum strength
- blow molded transit case
- built in wheels, handle
- light storage in the lid

### Roll Wrap: OCP-C2C-G

- available in fabric or graphic
- converts OCP to a counter
- polymer counter surface exposed

### Stretch Wrap: OCP-SW-G

- stretch fabric pullover
- converts OCP to a counter
- polymer counter surface covered by fabric

## OCP2 CASE TO COUNTER CONVERSION



### OCP2

- new premium latches for maximum strength
- hinged lid with internal light storage
- robust, roto-molded plastic

### Roll Wrap: OCP2-C2C-G

- available in fabric or graphic
- converts OCP2 to a counter
- polymer counter surface exposed

### Stretch Wrap: OCP2-SW-G

- stretch fabric pullover
- converts OCP2 to a counter
- counter surface covered by fabric

## OCP ELITE CASE TO COUNTER CONVERSION



### OCP-ELITE

- heavy duty shipping and storage case
- lid can be used as a step stool
- access door provides storage when unit is used as a counter
- UPS approved

### Roll Wrap: ELITE-C2C-G

- available in fabric or graphic
- converts OCP Elite to a counter
- counter surface exposed

### Stretch Wrap: ELITE-SW-G

- stretch fabric pullover
- converts OCP Elite to a counter
- counter surface covered by fabric



All molded cases have a one year limited hardware warranty and are an eco-friendly choice.

## COYOTE™ MINI

- approx. 20% smaller than standard Coyote™ tabletops
- entire display rolls up into special storage sleeve which slides into a padded carry case
- kit includes frame, channel bars, front curved graphic panels, carry case & 2 lights
- add an optional OCS hard case for shipping or extra secure storage

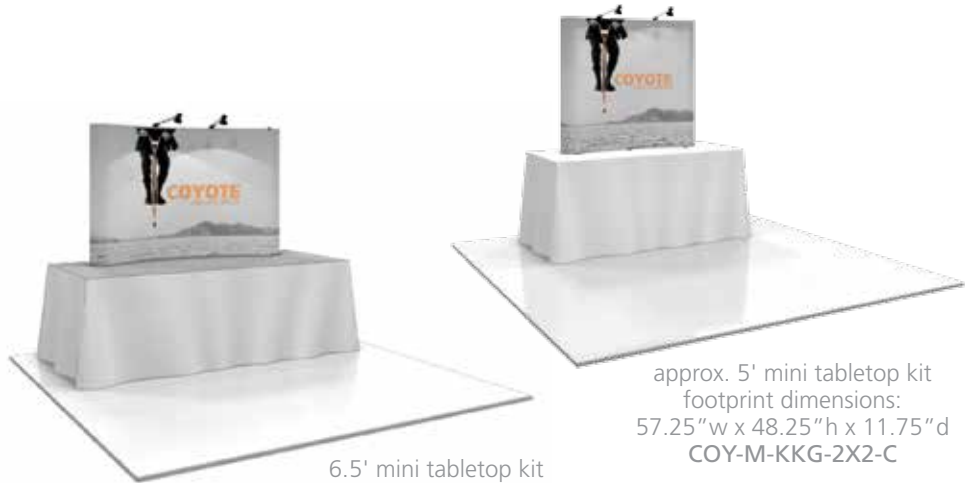

6.5' mini tabletop kit  
footprint dimensions:  
77.5" w x 48.25" h x 16.25" d  
COY-M-KKG-3X2-C

approx. 5' mini tabletop kit  
footprint dimensions:  
57.25" w x 48.25" h x 11.75" d  
COY-M-KKG-2X2-C



easy rollup carry bag holds Coyote™ Mini hardware and graphics

## BUBBLE PANEL

COY-K-GBBP-O

- forward facing, convex panel
- panel can be fabric, opaque graphic or rear illuminated graphic (light kit sold separately)
- hardware can be stored with display in OCP



## MONITOR MOUNT

COY-MM

- fully integrates with straight or curved Coyote™ systems
- one panel cut to fit the monitor\*
- VESA bolt compatible
- max weight = 50 lbs
- LCD max size = 23"



not recommended for plasma or CRT units



## INTERNAL SHELF KIT

COY-IS-CK

- presents products or literature
- comes with 2 clear acrylic shelves to be used horizontally or at 45° angles
- max capacity per shelf = 15 lbs, max per quadrant = 45 lbs
- for use with curved frame only
- lighting package available (not to be stored with display in OCP)



## COYOTE™ TOWER

COY-3-G-TOW

- an unexpected addition to any display; large or small, exhibit or P.O.P.
- back-lit panels illuminate your graphics (optional upgrade)
- coordinates with the look and style of your Coyote™ popup display



\*monitor not included



All Coyotes come with a limited lifetime hardware warranty.





# **BOLD.SOPHISTICATED.FABRIC. FORMULATE™ TENSION FABRIC**

Formulate™ is a collection of sophisticated, ergonomically-designed exhibit booths, architectural structures and accessories • Formulate displays feature simple and stylish aluminum frames, covered by stretch pillowcase fabric graphics • Formulate tension fabric displays come in essential and master quality options • Available in a variety of sizes and options

## WHERE FORM MEETS FABRIC

From straight and angular shapes to ergonomic, flowing ones we offer a full spectrum of beautiful fabric-based exhibits, environments and structures, portable to custom. Make your exhibit and environment exactly what you want it to be. Formulate™ solutions combine shape, specialty fabrics, lightweight frames and lighting to create captivating and artistic presentations and spaces.

### Shapes to mix & match...

Lightweight aluminum frames are coupled with stretch, zipper pillowcase fabric graphics to create shapes that foster emotion, action and movement within and around a space. Formulate master fabric structures are formed with expert aluminum bending machinery and skilled welding technicians. We offer a complete line of tension fabric backwalls, exhibit kits, hanging shapes and structures, towers, archways, walls, rooms and more. With the endless options we provide, you can mix and match to create the ideal display, booth or environment or work with us to create a custom solution from scratch.

From fast, portable, off-the-shelf displays to completely custom FABRICated exhibits and solutions, we deliver the solution you need in the time that you need it. Whether you are looking for a tension fabric tradeshow display, or adding function through form in an interior space or retail environment, we provide a one-stop-shop for both sides of the spectrum and everything in between.

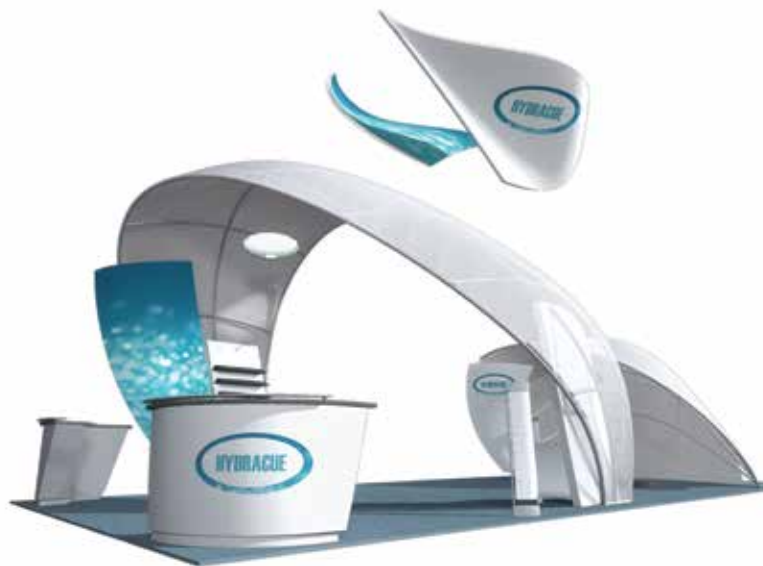

# WHERE **FABRIC** MEETS **FORM**

## **Specialty fabrics...**

Materials do matter. Each fabric used has unique qualities and performs differently in various environments. We use a plethora of high-quality printable materials to create fabric structures and displays – namely polyester materials such as stretch, satins, sheers, backlit fabrics and more.

## **Grand format graphics & finishing...**

Graphics are crucial to maximizing your messaging impact and your investment in a tradeshow or event. With the latest state-of-the-art printing technology and large format printing capabilities, we ensure your message pops and stands out from the competition. To ensure the highest quality and perfect fit, all fabric graphics are produced and finished by hand by highly-skilled sewers in the USA.

## **Radiant lighting ...**

The perfect balance of form, fabric and lighting can create a powerful, impactful presence and display. Illumination is an important piece of the puzzle to achieve the mood, style and staging that you desire. With LED lighting solutions, we can tailor the ideal lighting system to make your project glow!

Merging shapes and structures with fresh fabric, large format print graphics and lighting creates dynamic and eye-catching displays for tradeshows, events, retail spaces and interior environments.





Formulate VC10  
FMLT-WV10-10



Courtesy of: Neebo & Lines and Designs

## FORMULATE TENSION **FABRIC**

The FORMulate™ line spans from a collection of portable, off-the-shelf exhibit kits, hanging structures and architectural accessories to custom-designed and built exhibits, environments and interior display solutions. Formulate combines state-of-the-art zipper pillowcase dye-sublimated fabric coverings with advanced lightweight aluminum tube structures to provide elegance, functionality and style.

The quality of the Formulate line is excellent. The perfect combination of form, sophistication and function make Formulate displays the ideal solution for any space. All Formulate stretch fabric graphics are printed on state-of-the-art, G7 color certified printers and are hand-sewn, durable and dry-cleanable.

The Formulate line includes tabletop, 8ft, 10ft and 20ft backwalls and exhibit kits, 20ft by 20ft island exhibit kits, hanging structures, towers, columns, funnels, archways, counters and more. Easily mix and match to create your ideal display, exhibit or environment or work with us to create a custom solution from scratch.

NO MATTER WHAT YOUR SPACE NEEDS, WE CAN **FORM** A SOLUTION FOR YOU.



**FORMULATE ESSENTIAL  
TABLETOP DISPLAYS**

Formulate™ Essential Tabletop displays have customary frame features, are portable and come in Straight, Vertical Curved and Horizontal Curved options. The economy aluminum tube frame features bungee cords, rounded corners and comes with a one year limited warranty. Simply pull the pillowcase fabric graphic over the frame and zip. All displays have an overall height of 5ft and fit on a 6ft wide table and come with a canvas carry bag.

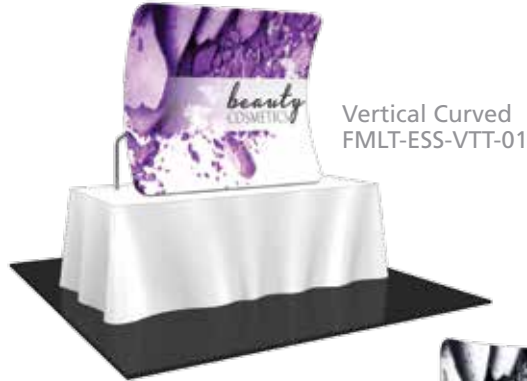

Vertical Curved  
FMLT-ESS-VTT-01



Straight  
FMLT-ESS-STT-01



Horizontal Curved  
FMLT-ESS-HTT-01

**FORMULATE ESSENTIALS  
8' DISPLAYS**

Formulate™ Essential 8ft displays have customary frame features, are portable and come in Straight, Vertical Curved and Horizontal Curved options. The economy aluminum tube frame features bungee cords, rounded corners and comes with a one year limited warranty. Simply pull the pillowcase fabric graphic over the frame and zip. All displays come with a canvas carry bag.



Straight  
FMLT-ESS-S08-01



Horizontal Curved  
FMLT-ESS-H08-01



Vertical Curved  
FMLT-ESS-V08-01

FORMULATE ESSENTIAL  
**10' DISPLAYS**

Formulate™ Essential 10ft displays have customary frame features, are portable and come in Straight, Vertical Curved, Horizontal Curved and Serpentine Curved options. The economy aluminum tube frame features bungee cords, rounded corners and comes with a one year limited warranty. Simply pull the pillowcase fabric graphic over the frame and zip. All displays come with a canvas carry bag.



Vertical Curved  
FMLT-ESS-V10-01



Straight  
FMLT-ESS-S10-01



Horizontal Curved  
FMLT-ESS-H10-01



Serpentine Curved  
FMLT-ESS-SC10-01

# formulate™ lite | 8' DISPLAYS

## FORMULATE LITE 8'/10' DISPLAYS

Looking for a sharp, simple, portable fabric backdrop that sets up in 5 minutes or less? Look no further. The Formulate™ Lite 8ft by 10ft fabric backdrop is one of the fastest and easiest solutions you can find. In addition to the standard landscape/horizontal configuration, Formulate Lite can be turned on its side to create a portrait/vertical wall as well.

The sturdy, lightweight 30mm aluminum frame assembles with push-button functionality. Simply stretch the graphic over the corners of the frame and you're done. You have an instant, impressive fabric backdrop!

The Formulate Lite kit is supplied in a carry bag. Shown with an optional, upgraded OCB case.



Formulate Lite -  
landscape/horizontal graphic



Formulate Lite - portrait/vertical graphic  
FMLT-LT-01







Formulate TT1  
FMLT-WTT-V01



## FORMULATE TABLETOP DISPLAYS

Having a small space doesn't mean you can't make a big impact! Formulate™ Master Tabletop displays are lightweight, highly-portable and come in Straight and Vertical Curved options. The frame assembles with easy-to-use snap buttons, then simply pull the pillowcase fabric graphic over the frame and zip. All displays have an overall height of 46.5 inches, fit on a 6ft wide table and come in a convenient, transit case.



Formulate TT2  
FMLT-WTT-V02

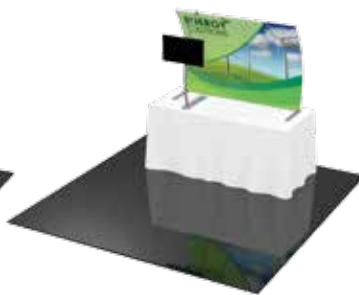

Formulate TT3  
FMLT-WTT-V03



Formulate TT4  
FMLT-WTT-S01

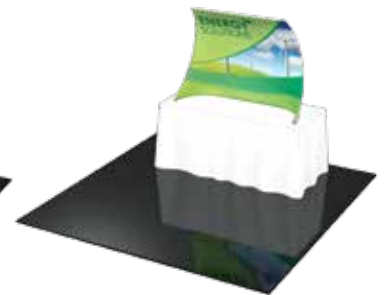

Formulate TT5  
FMLT-WTT-S02



Formulate 8H  
FMLT-WH8-01



Formulate 8S  
FMLT-WS8-01



Formulate 8V  
FMLT-WV8-01

## FORMULATE MASTER 8' DISPLAYS

Simplicity and style make Formulate™ Master 8ft displays an ideal solution. Available in Straight, Vertical Curved and Horizontal Curved options, Formulate Master 8ft displays are easy-to-assemble with snap-button tube functionality and pull-over zipper pillowcase fabric graphics. All displays come in a portable, wheeled transit case.

# formulate™ master | 10' VERTICAL CURVED DISPLAYS

## FORMULATE MASTER 10' VERTICAL CURVED DISPLAYS

Slightly arched from top to bottom, Formulate™ Master 10ft Vertical Curved exhibits combine pillowcase fabric graphics with lightweight aluminum tube frames to form fashionable and functional exhibits. Accessories such as headers, adjustable literature holders, tables and accents provide enhanced functionality and more real estate for messaging. The wide array of Formulate Master Vertical Curved kits and accessories make it easy to glamorize any 10ft space.



Courtesy of:  
CamelbackDisplays.com



Courtesy of: Motif Events



Courtesy of: Worldwide  
Graphics & Sign Company

# 10' VERTICAL CURVED DISPLAYS | formulate™ master



Formulate VC1  
FMLT-WV10-01



Formulate VC2  
FMLT-WV10-02



Formulate VC3  
FMLT-WV10-03



Formulate VC4  
FMLT-WV10-04



Formulate VC5  
FMLT-WV10-05



Formulate VC6  
FMLT-WV10-06



Formulate VC7  
FMLT-WV10-07



Formulate VC8  
FMLT-WV10-08



Formulate VC9  
FMLT-WV10-09

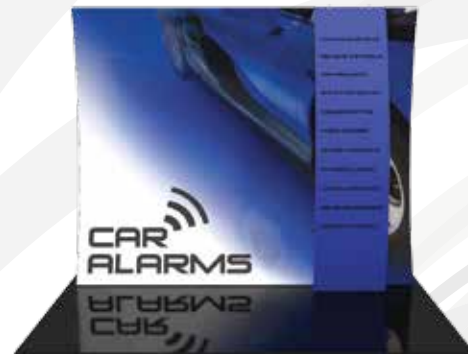

Formulate VC11  
FMLT-WV10-11

\*monitors not included

# formulate™ master | 10' HORIZONTAL CURVED DISPLAYS

## FORMULATE MASTER 10' HORIZONTAL CURVED DISPLAYS

Ergonomically designed, Formulate™ Master 10ft Horizontal Curved exhibits combine the latest developments in fabric printed technology with a gently curved aluminum frame to create a seamless, elegant exhibit that enhances the message of your exhibit or environment. Accents provide added functionality and messaging areas. With so many choices, you're sure to find a design that suits your desire for style!



Courtesy of: Hanscom  
Federal Credit Union

10' HORIZONTAL CURVED DISPLAYS | **formulate™ master**



Formulate HC1  
FMLT-WH10-01



Formulate HC2  
FMLT-WH10-02

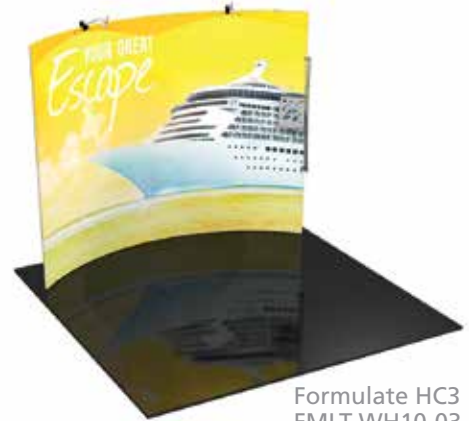

Formulate HC3  
FMLT-WH10-03

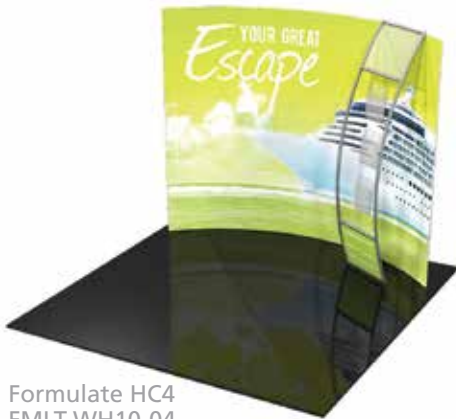

Formulate HC4  
FMLT-WH10-04



Formulate HC5  
FMLT-WH10-05

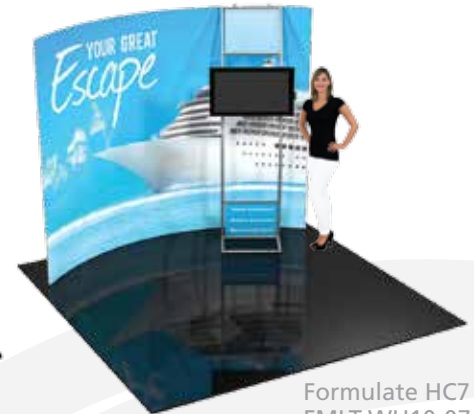

Formulate HC7  
FMLT-WH10-07



Formulate HC8  
FMLT-WH10-08



Formulate HC9  
FMLT-WH10-09



Formulate HC10  
FMLT-WH10-10

\*monitors not included

# formulate™ master | 10' STRAIGHT DISPLAYS

## FORMULATE MASTER 10' STRAIGHT DISPLAYS

Space maximizing Formulate™ Master 10ft Straight exhibits incorporate sleek, straight aluminum frames with zipper pillowcase fabric graphics to create a sharp, bold backwall that clearly conveys who you are and what you do. With a variety of accents including graphic headers, adjustable literature pockets, shelves, tables, counters and more, you are sure to find a design that best suits your space needs!



Formulate S5  
FMLT-WS10-05



Formulate S1  
FMLT-WS10-01



Formulate S2  
FMLT-WS10-02



Formulate S3  
FMLT-WS10-03



Formulate S4  
FMLT-WS10-04



Formulate S6  
FMLT-WS10-06



Formulate S7  
FMLT-WS10-07

FORMULATE MASTER ACCENTS

Formulate™ Master Accents enhance the functionality of any Formulate Master 10ft or 20ft backwall and add more real estate for messaging too! With monitor supports, literature pockets, shelves, tables, counters and more, you are sure to find the accent that best suits your needs. Side tables and graphic headers also available.

**FORMULATE BACKWALL CONNECTOR**  
FMLT-WBWC

The Formulate™ Master Backwall Connector is an ideal accessory to connect two 10ft or 20ft Formulate backwalls. It features a pillowcase fabric graphic and connects easily to create the appearance of one seamless display.

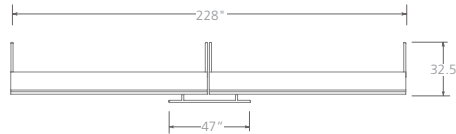

**ACCENT 01**  
FMLT-WL01  
Pillowcase fabric graphic



**ACCENT 02**  
FMLT-WL02  
Three 20" wide shelves and top and bottom printed infill panels



**ACCENT 03**  
FMLT-WL03  
FMLT-WL03-L  
FMLT-WL03-R  
Your choice of right-hand or left-hand arm tables, no table, top and bottom printed infill panels and hardware mounts for a medium sized monitor



**ACCENT 04**  
FMLT-WL04  
Features a 36" wide table top, top and bottom velcro applied printed fabric graphics and hardware mounts for a medium sized monitor



**ACCENT 05**  
FMLT-WLLH  
Three literature pockets, and top and bottom printed infill panels



**ACCENT 06**  
FMLT-WLC  
Features a 20" wide shelf and top and bottom printed infill panels

\*monitors not included

# formulate™ master | 20' SERPENTINE CURVED DISPLAYS

## FORMULATE MASTER 20' SERPENTINE CURVED DISPLAYS

The gentle and organic S-shaped curves of the Formulate™ Master Serpentine line of 20' exhibits create an elegant flow within a space. These displays can feature a single-sided or double-sided fabric graphic, which provides more real estate for branding and messaging. Pillowcase style fabric graphics are coupled with sturdy, yet lightweight aluminum frames to create the unique and flowing Serpentine shape. Accents provide shelving, surface areas, monitor displays and additional messaging areas.



Formulate SC2  
FMLT-WSC-20-02

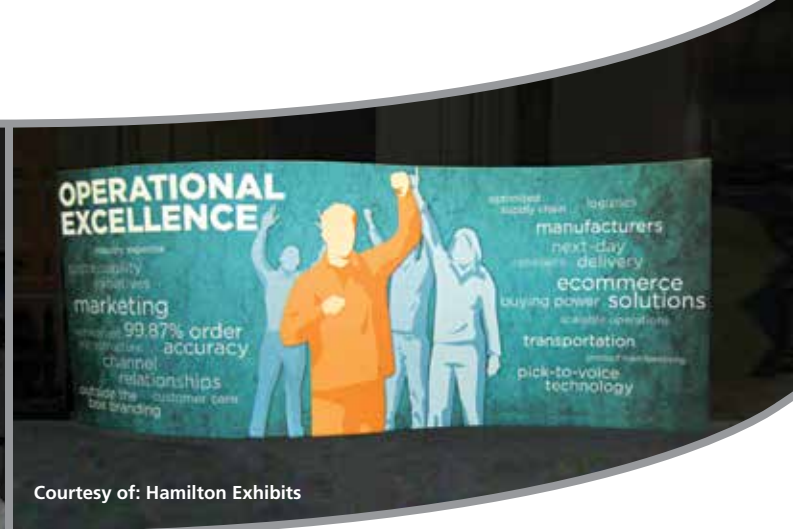
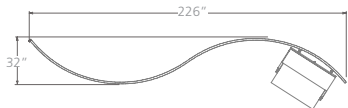

Courtesy of: Hamilton Exhibits



20' SERPENTINE CURVED DISPLAYS | **formulate™ master**



Formulate SC1  
FMLT-WSC20-01

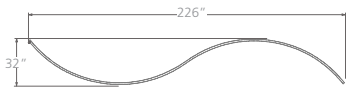

Formulate SC3  
FMLT-WSC20-03

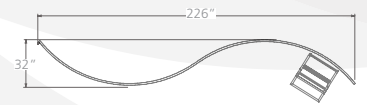

Formulate SC4  
FMLT-WSC20-04

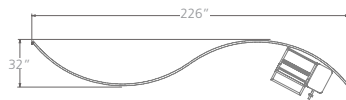

Formulate SC5  
FMLT-WSC20-05

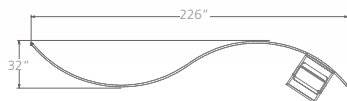

Formulate SC6  
FMLT-WSC20-06

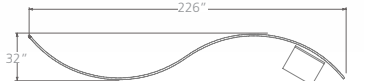

\*monitors not included

# formulate™ master | 20' VERTICAL CURVED DISPLAYS

## FORMULATE MASTER 20' VERTICAL CURVED DISPLAYS

Slightly arched from top to bottom, Formulate™ Master 20ft Vertical Curved displays combine pillowcase fabric graphics with lightweight aluminum tube frames to form fashionable and functional exhibits. Accents provide enhanced functionality and more real estate for messaging. The wide array of Formulate Master Vertical Curved kits and accessories make it easy to glamorize any 20ft space. Easily convert the 20ft Master Vertical Curve Formulate to a 10ft backwall with the purchase of a 10ft graphic. No additional hardware needed.



Formulate WV3  
FMLT-WV20-03

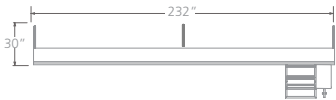

easily  
converts to a  
10' backwall



10' Vertical  
Curved Backwall



Courtesy of: Eco Exhibits/Advantum Displays



Courtesy of: Eye Catching Solutions



Formulate WV1  
FMLT-WV20-01



Formulate WV2  
FMLT-WV20-02



Formulate WV4  
FMLT-WV20-04

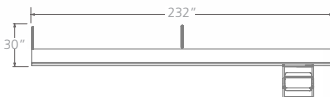

Formulate WV5  
FMLT-WV20-05



\*monitors not included

# formulate™ master | 20' HORIZONTAL CURVED DISPLAYS

## FORMULATE MASTER 20' HORIZONTAL CURVED DISPLAYS

Ergonomically designed, Formulate™ 20ft Master Horizontal Curved exhibit kits combine the latest developments in fabric printed technology with a gently curved aluminum frame to create a seamless, elegant exhibit that enhances the message of your exhibit or environment. Accents provide added functionality and messaging areas. With so many choices, you're sure to find a design that suits your desire for style! Easily convert the 20ft Master Horizontal Curve Formulate to a 10ft backwall with the purchase of a 10ft graphic. No additional hardware needed.



Formulate WH4  
FMLT-WH20-04



easily  
converts to a  
10' backwall



10' Horizontal  
Curved Backwall



Formulate WH1  
FMLT-WH20-01

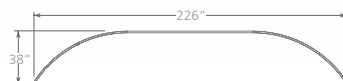

Formulate WH2  
FMLT-WH20-02

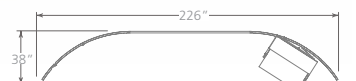



Formulate WH3  
FMLT-WH20-03



Formulate WH5  
FMLT-WH20-05



Formulate WH6  
FMLT-WH20-06



LCD monitors not included.



Formulate 20 Straight  
FMLT-WS20-01





## FORMULATE MASTER 20' STRAIGHT DISPLAY

The Formulate™ 20ft Master Straight backwall incorporates a sleek, straight aluminum frame with a zipper pillowcase fabric graphic to create a sharp, bold backwall that clearly conveys who you are and what you do. Print on just one side or on both sides of the graphic to maximize your message and brand exposure!

# SPIN OR FLIP

TO CREATE A DIFFERENT LOOK  
& SHOW A NEW MESSAGE!

 **SPIN** FROM **FRONT TO BACK** TO SHOW A  
DIFFERENT MESSAGE OR BRAND! 



### FLIP 20' EXHIBIT KITS

FLIP™ 20ft exhibits incorporate layered, staggered walls that are connected to create a unique, dimensional and versatile display.

#### SO FLIPPIN' COOL

Double-sided graphics enable you to feature a different look, brand or messaging so you can **SPIN from front to back** OR use as a creative space divider for a larger space. With an easy graphic change, you can also **FLIP from top to bottom** to create a new, different exhibit and look for your next event. With the versatility of FLIP, you have many options to reconfigure over and over for a long-lasting, ever-changing display.

#### SO FLIPPIN' EASY

FLIP kits combine 30mm lightweight aluminum frames with your choice of single or double-sided zipper pillowcase fabric graphics. Simply join the aluminum tubes together with snap-button connectors, slide the fabric graphics over the frames, then zip. Connect the walls and WHALA, you have one of the coolest and most versatile displays in the event. It's that easy.

**FLIP** FROM TOP TO BOTTOM TO CREATE A NEW LOOK FOR ANOTHER EVENT!



## FLIP 20' EXHIBIT KITS

FLIP™ 20ft exhibits incorporate layered, staggered walls that are connected to create a unique, dimensional and versatile display.

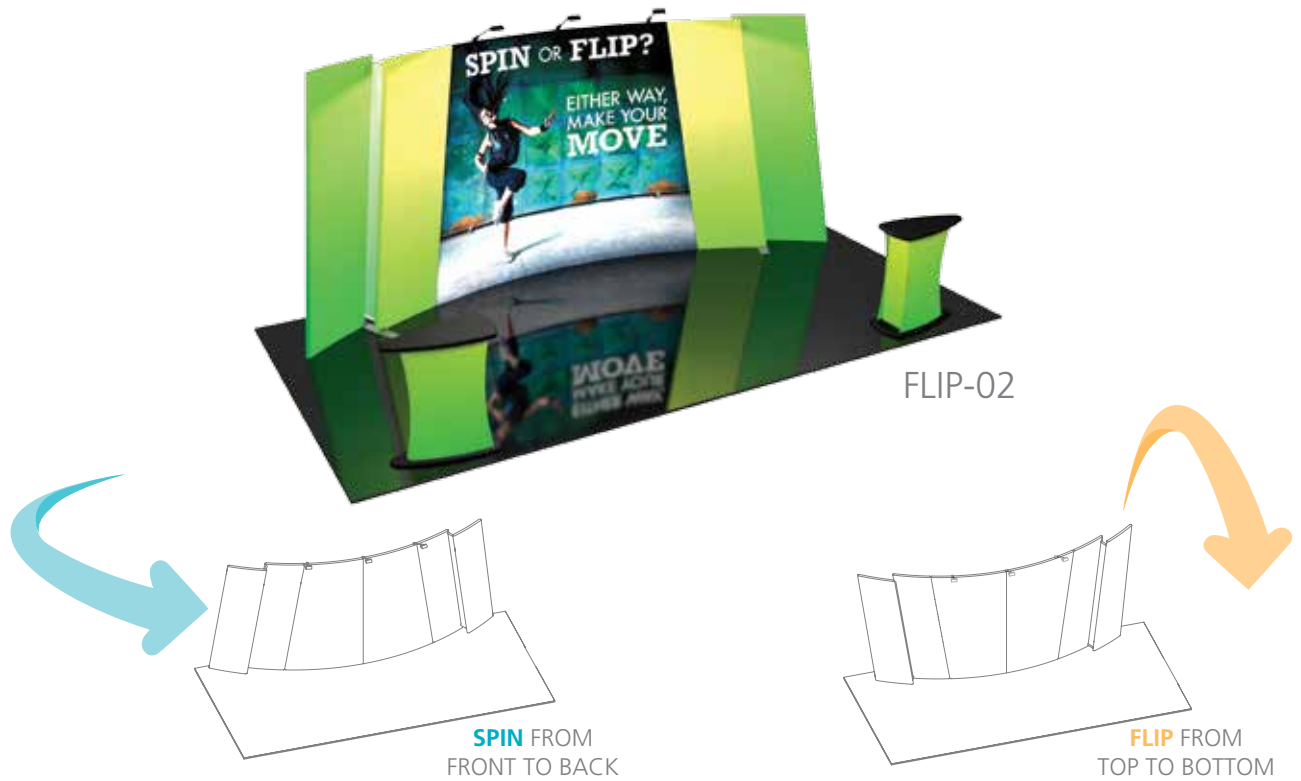
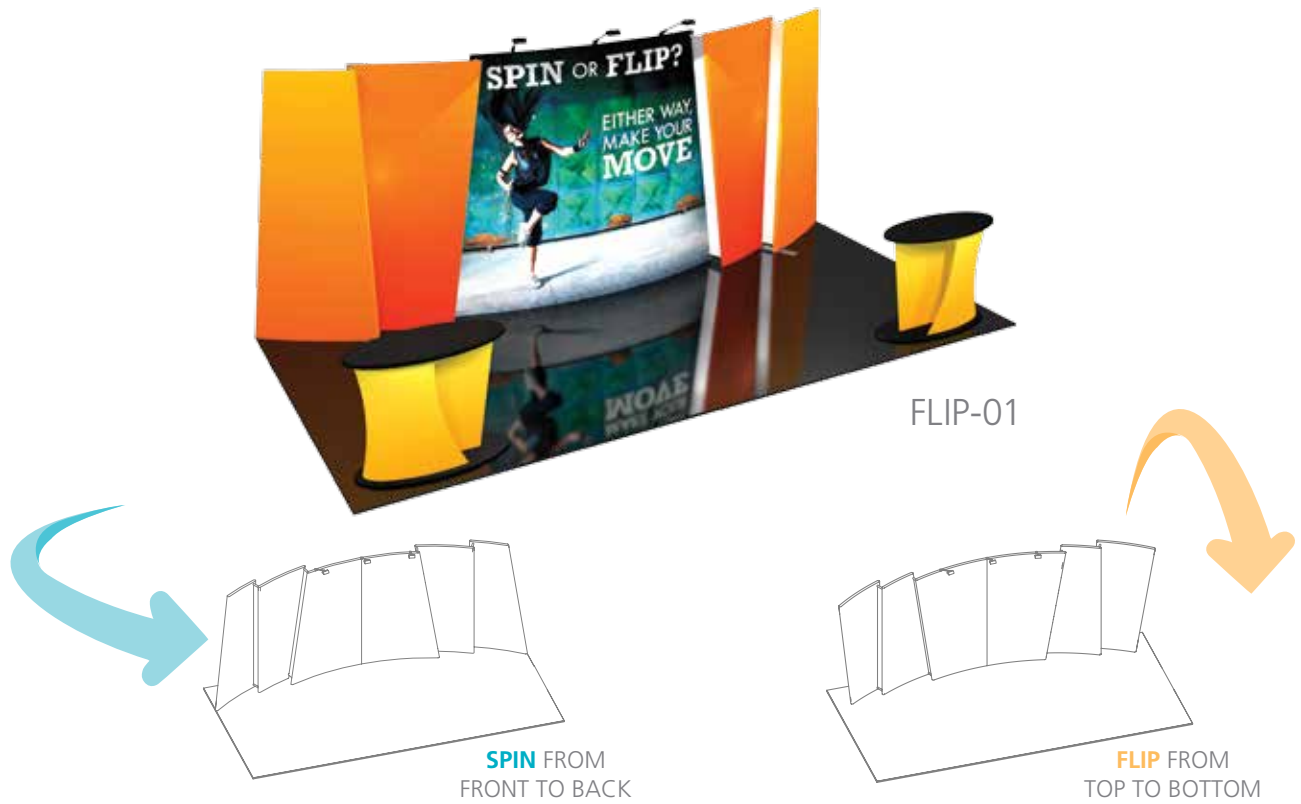

\*Counters, lighting and lighting hardware not included in kits. A la carte counter options presented on page 124. Lighting presented on page 135.



FLIP 20' EXHIBIT KITS

Ask to incorporate LED lights to make your FLIP™ display shine.



FLIP-03

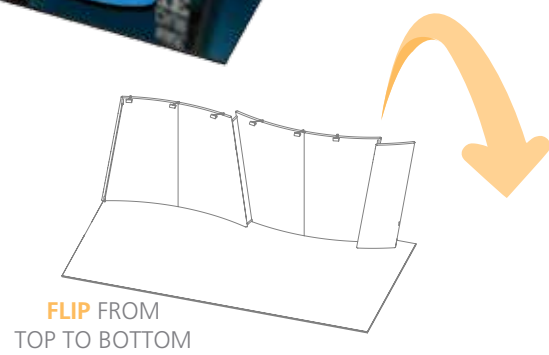
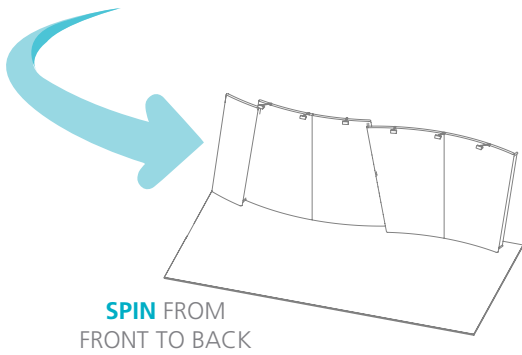

FLIP-04

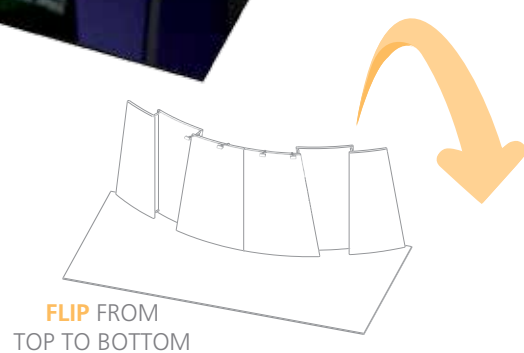
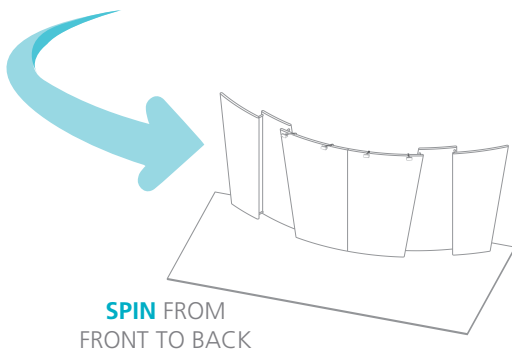

\*Counters, lighting and lighting hardware not included in kits. A la carte counter options presented on page 124. Lighting presented on page 135.

## VIBE 10' EXHIBIT KITS

Vibe™ is a collection of cleverly-designed, dimensionally layered 10ft exhibit kits. Vibe combines layered lightweight aluminum tube frames with zippered pillowcase printed fabric graphics. Unique shapes, angles and exposed framework create a truly unique appearance and experience. Where they appear, kits include graphic headers, lights and monitor kiosks to provide additional branding and messaging areas.





KIT 01  
VBK-1



KIT 02  
VBK-2



KIT 03  
VBK-3



KIT 04  
VBK-4

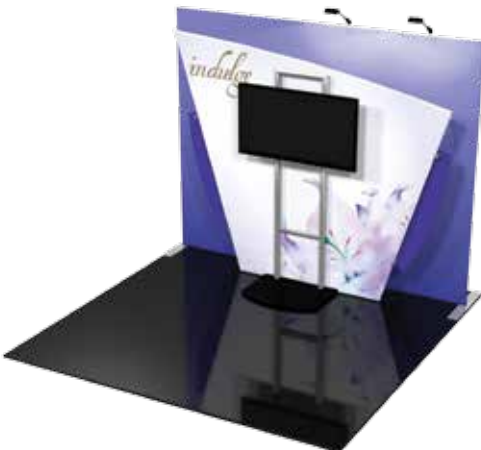

KIT 06  
VBK-6



**VIBE MONITOR  
KIOSK**  
VB-MK-01

Simply add the Vibe™ kiosk to create an interactive, multimedia display. Kiosk comes with a monitor bracket that holds a max weight of 50lbs and a convenient, portable shipping case. Monitor is not included with kiosk or kit.

# formulate™ fusion | 20' x 20' ISLAND EXHIBIT KITS

## FORMULATE FUSION

Formulate™ Fusion provides an unparalleled dynamic that elevates and accentuates a message and brand, but also maximizes the return on tradeshow investment. Formulate Fusion is a collection of 20ft by 20ft exhibit kits and custom solutions. A fusion of FORM, FABRIC and FUNCTION, these kits combine organic and architectural shapes with state-of-the-art zipper pillowcase dye-sublimated fabric graphics to create unique, dynamic and functional island spaces.



### KIT 01

CFAB-K-01

Add the WOW factor to your next tradeshow with this commanding and captivating 20ft by 20ft island display.

Formulate™ Fusion Kit 1 weaves together FORMulated structures that combine the latest developments in fabric printed technology with heavy-duty, structurally-sound aluminum frame structures to create a space that encourages traffic flow and provides stylish product display and messaging areas.

The 16ft tall fabric tower centerpiece connects to four 8ft tall fabric-based product display areas. A 14ft diameter ring structure not only provides an ideal area for branding and messaging, but it also weaves the elegant tower and product display areas together. Two fabric reception counters provide fashionable, and functional greeting areas. Monitor mounts and stylish display lighting are included. Internal LED light kits are not included, but can be purchased a la carte to add a glow within the tower and reception counters.

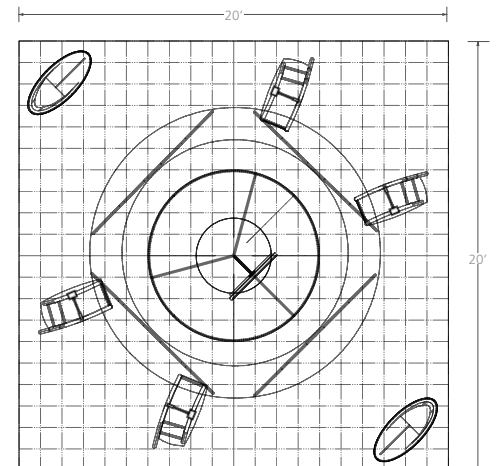



**KIT 02**  
CFAB-K-02

You won't get bypassed with this 20ft by 20ft island exhibit in your next event or tradeshow!

Formulate™ Fusion Kit 2 features a fabric archway, a dimensional hanging structure and curved conference area to create a space that fosters flow, yet provides privacy for meetings and demonstrations. Each display element combines state-of-the-art zipper pillowcase dye-sublimated fabric coverings with advanced lightweight aluminum tube structures.

The overhead hanging structure is 13ft wide, 5ft tall and 1ft thick, providing ample space for a company brand. The prominent arch spans 14ft wide and reaches 11 ½ft high. An 8ft tall by 9 ½ft wide fabric backwall is positioned behind the fabric display counter to add a messaging area, privacy and a display surface on the interior side. An 8ft tall "potato chip" shaped, curved fabric wall creates a semi-private conference/meeting area or projection wall within the space. Monitor mounts and stylish display lighting are included. Internal LED light kits are not included, but can be purchased a la carte to add a glow within the reception counter and backwall.

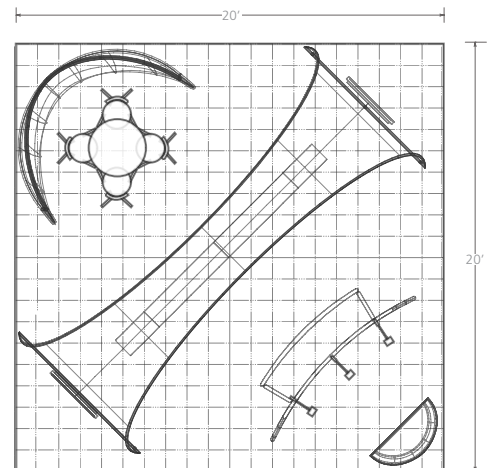

# formulate™ fusion | 20' x 20' ISLAND EXHIBIT KITS



## KIT 03 CFAB-K-03

Captivate your audience inside this 20ft by 20ft island display at your next event!

Formulate™ Fusion Kit 3 features a commanding and angled fabric architectural structure, reception areas and more! The angled, architectural tunnel is 16ft tall on one side and 12ft tall on the other and is the perfect space for an intimate and semi-private presentation, conference or theater area. This stylish and functional island display kit also includes two fabric-based reception counters that function as ideal greeting and storage areas. Additionally, a fabric-based refreshment bar is located inside the theater space, which also features additional storage space.

Monitor mounts and stylish display lighting are included. Internal LED light kits are not included, but can be purchased a la carte to add a glow within the reception counters.

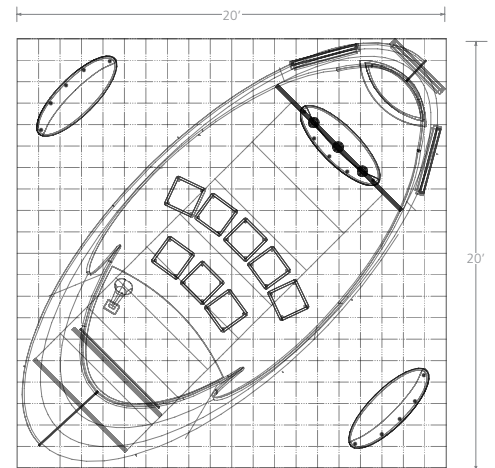



**KIT 04**  
CFAB-K-04

Demo, demo, demo! You have ample demonstration and meeting space with this 20ft by 20ft island exhibit!

Fabric canopies and messaging areas are combined with a heavy-duty laminate-based tower and cabinets to create a space that provides three product display/demonstration stations and two seating areas. The layout of this exhibit fosters traffic flow within the space and provides real estate for demonstrations.

Formulate™ Fusion Kit 4 features an 18ft tall laminate panel tower connected to three 12ft long wave-shaped canopies. The tower features ample lockable storage space. Stemming from the three canopies are 10 ½ft tall fabric and extrusion based messaging and product display walls, which are anchored to laminated, lockable cabinets. Graphic headers on the display walls are 4ft wide and provide the ideal space for branding or product information.

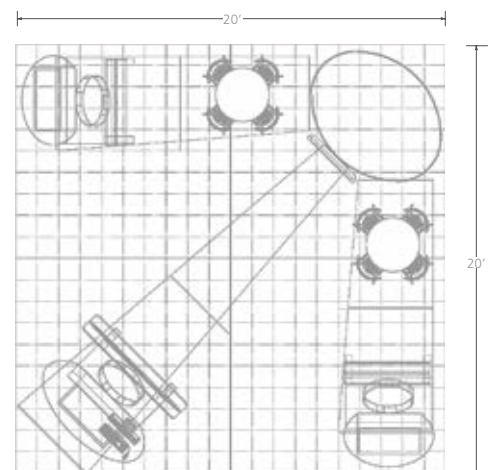

# formulate™ fusion | 20' x 20' ISLAND EXHIBIT KITS



## KIT 05 CFAB-K-05

Dominate the exhibit hall with this 20ft by 20ft island exhibit and stand out from the rest!

Formulate™ Fusion Kit 5 combines architectural lines and shapes with the latest developments in fabric to create a sophisticated, memorable and breathtaking presence.

The 18ft tall fabric covered tower centerpiece features a 7ft diameter cone and three curved architectural support beams. You can easily incorporate monitors and AV into the support structures to add multimedia messaging. A laminate counter with printed slat walls provides a welcoming reception area, as well as abundant lockable storage.

Monitor mounts are included. Internal LED light kits are not included, but can be purchased a la carte to add a glow within the support structures.

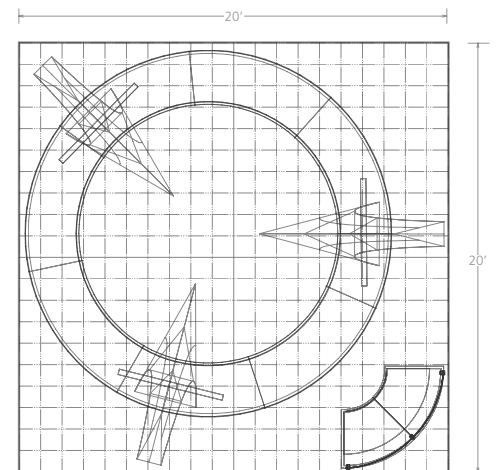



## CUSTOM FORMULATE

We can also FABRICate a completely custom and ultra-creative exhibit and environment solution for you. Each custom FORMulated solution is uniquely designed, manufactured and custom crafted from a selection of sizes and styles of aluminum tube, which are blended with the very best-suited stretch fabric graphics and lighting.

With over 30 years of proven excellence in the design, construction, project management and fulfillment of custom and custom modular exhibit solutions, we have what it takes to build a custom booth, environment and interior space. Concept to design, then design to production, we can provide custom fabric exhibit structures as a seamless turnkey service through to installation, dismantle and post-show storage.



**KIT 06**  
CFAB-K-06

An airy floor plan encourages maximum traffic flow into this 20ft by 20ft island exhibit!

Formulate™ Fusion Kit 6 features structures that combine the latest developments in fabric printed technology with heavy-duty aluminum frames to create a space that fosters great traffic flow and conversation areas.

The 12ft tall center fabric tower is connected to two 9ft tall fabric towers via exposed aluminum tube. Oval-shaped sintra panels are located on front and back sides of the aluminum tubes providing four messaging and branding areas. An oval-shaped fabric reception counter provides a fashionable, yet functional greeting area. Additionally, an 8ft tall "potato chip" shaped, curved fabric wall creates a semi-private conference/meeting area or projection wall within the space.

Six monitor mounts are included. Internal LED light kits are not included, but can be purchased a la carte to add a glow within the three tower structures and reception counter.

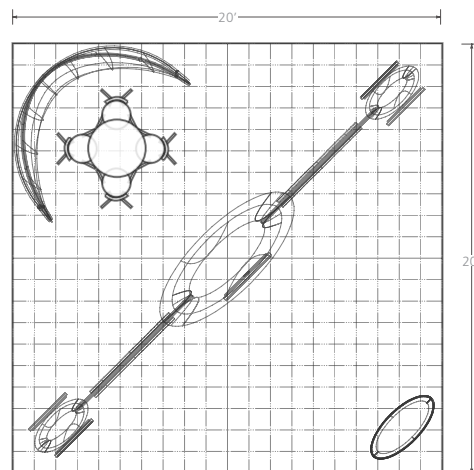

## FORMULATE HANGING STRUCTURES

Hanging structures are used to attract and command attention to your tradeshow booth or use as a focal point at an event or in an interior space. Project from all angles and draw the eye to your brand to proclaim your message! With a wide variety of three and two-dimensional structures and shapes to choose from, you're sure to find the best solution to draw attention and create a dramatic affect in any space.

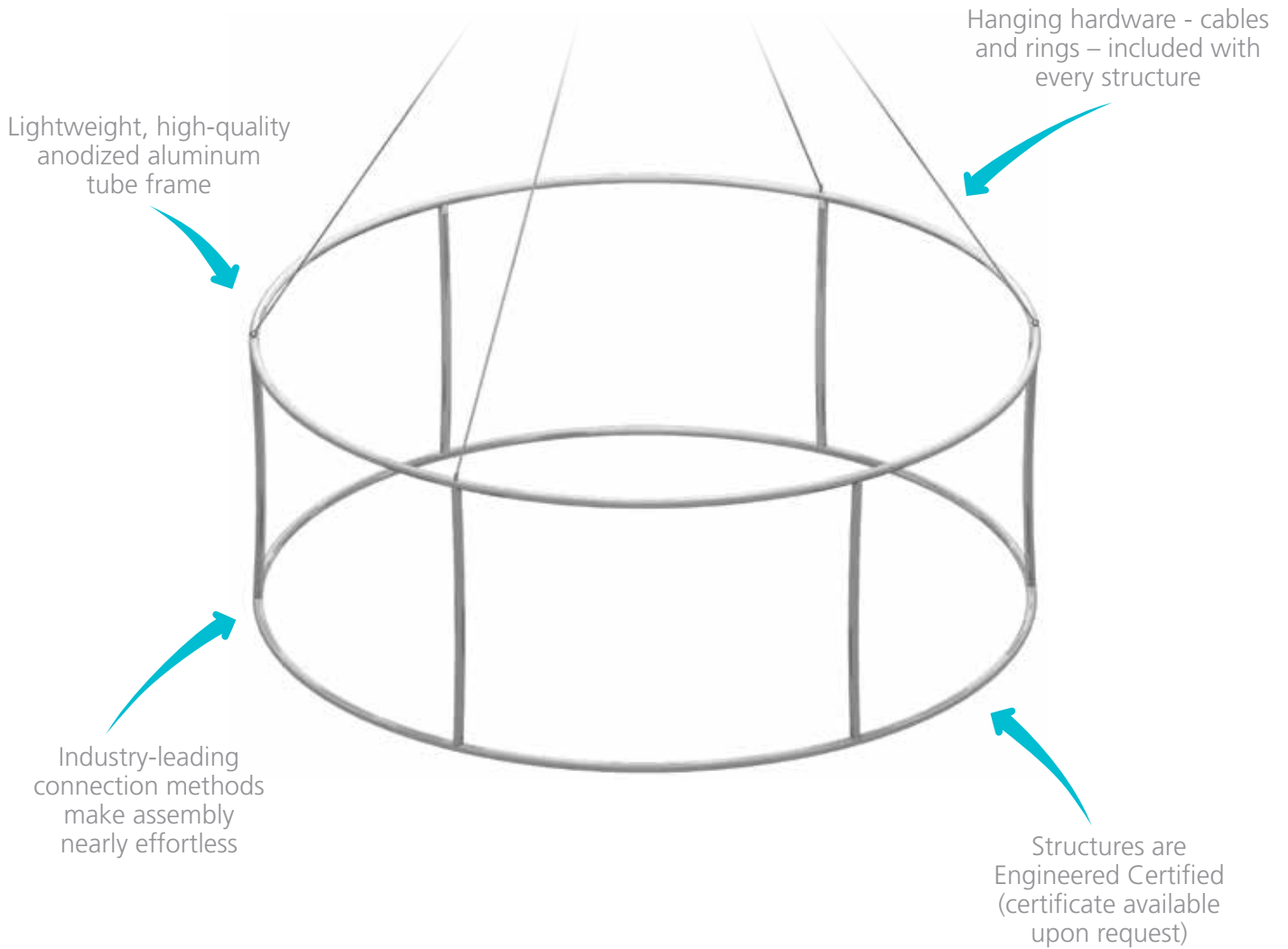

OCE – Formulate Expandable Case

Structures collapse to a fraction of their size and come in standard in carry bags and heavy-duty shipping and storage box(es).

Expandable, rugged molded shipping and transportation cases available as an upgrade.

Formulate™ tension fabric hanging structures are made in the USA and are of the utmost quality and durability. Formulate combines state-of-the-art zipper pillowcase dye-sublimated stretch fabric coverings with advanced, lightweight aluminum structures to provide unique design, functionality, and style. The excellence of the Formulate line of hanging structures is simply unmatched!

Fabric printing process provides G7 color-certified, SUPERIOR brilliant and vivid graphics

Tensioned, zippered pillowcase style fabric graphics are easy to slip on and off



Stretch fabric graphics are hand-sewn in the USA, durable and dry-cleanable

All graphics come with an opaque liner at no additional cost



Choose from these graphic options: blank, single-sided, double-sided, and zip-in blank and printed bottom panels

RING

8' diam. x 2'h/3'h/4'h/5'h/6'h  
 10' diam. x 2'h/3'h/4'h/5'h/6'h  
 12' diam. x 2'h/3'h/4'h/5'h/6'h  
 14' diam. x 2'h/3'h/4'h/5'h/6'h  
 16' diam. x 2'h/3'h/4'h/5'h/6'h  
 18' diam. x 2'h/3'h/4'h/5'h/6'h  
 20' diam. x 2'h/3'h/4'h/5'h/6'h

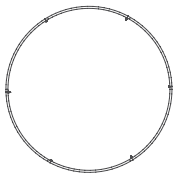

double-sided graphic



bottom graphic

TAPERED RING

8' diam. x 2'h/3'h/4'h/5'h/6'h  
 10' diam. x 2'h/3'h/4'h/5'h/6'h  
 12' diam. x 2'h/3'h/4'h/5'h/6'h  
 14' diam. x 2'h/3'h/4'h/5'h/6'h  
 16' diam. x 2'h/3'h/4'h/5'h/6'h  
 18' diam. x 2'h/3'h/4'h/5'h/6'h  
 20' diam. x 2'h/3'h/4'h/5'h/6'h

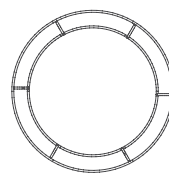

double-sided graphic

SQUARE

8'w x 2'h/3'h/4'h/5'h/6'h  
 10'w x 2'h/3'h/4'h/5'h/6'h  
 12'w x 2'h/3'h/4'h/5'h/6'h  
 14'w x 2'h/3'h/4'h/5'h/6'h  
 16'w x 2'h/3'h/4'h/5'h/6'h  
 18'w x 2'h/3'h/4'h/5'h/6'h  
 20'w x 2'h/3'h/4'h/5'h/6'h

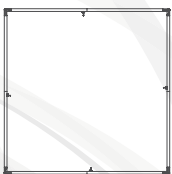

double-sided graphic



bottom graphic

TAPERED SQUARE

8'w x 2'h/3'h/4'h/5'h/6'h  
 10'w x 2'h/3'h/4'h/5'h/6'h  
 12'w x 2'h/3'h/4'h/5'h/6'h  
 14'w x 2'h/3'h/4'h/5'h/6'h  
 16'w x 2'h/3'h/4'h/5'h/6'h  
 18'w x 2'h/3'h/4'h/5'h/6'h  
 20'w x 2'h/3'h/4'h/5'h/6'h

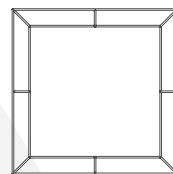

double-sided graphic

### CONCAVE SQUARE

8'w x 2'h/3'h/4'h/5'h/6'h  
 10'w x 2'h/3'h/4'h/5'h/6'h  
 12'w x 2'h/3'h/4'h/5'h/6'h  
 14'w x 2'h/3'h/4'h/5'h/6'h  
 16'w x 2'h/3'h/4'h/5'h/6'h  
 18'w x 2'h/3'h/4'h/5'h/6'h  
 20'w x 2'h/3'h/4'h/5'h/6'h



double-sided graphic

### TRIANGLE

8'w x 2'h/3'h/4'h/5'h/6'h  
 10'w x 2'h/3'h/4'h/5'h/6'h  
 12'w x 2'h/3'h/4'h/5'h/6'h  
 14'w x 2'h/3'h/4'h/5'h/6'h  
 16'w x 2'h/3'h/4'h/5'h/6'h  
 18'w x 2'h/3'h/4'h/5'h/6'h  
 20'w x 2'h/3'h/4'h/5'h/6'h



double-sided graphic



bottom graphic

### TAPERED TRIANGLE

8'w x 2'h/3'h/4'h/5'h/6'h  
 10'w x 2'h/3'h/4'h/5'h/6'h  
 12'w x 2'h/3'h/4'h/5'h/6'h  
 14'w x 2'h/3'h/4'h/5'h/6'h  
 16'w x 2'h/3'h/4'h/5'h/6'h  
 18'w x 2'h/3'h/4'h/5'h/6'h  
 20'w x 2'h/3'h/4'h/5'h/6'h

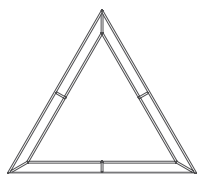

double-sided graphic

### CONVEX TRIANGLE (SHIELD)

8'w x 2'h/3'h/4'h/5'h/6'h  
 10'w x 2'h/3'h/4'h/5'h/6'h  
 12'w x 2'h/3'h/4'h/5'h/6'h  
 14'w x 2'h/3'h/4'h/5'h/6'h  
 16'w x 2'h/3'h/4'h/5'h/6'h  
 18'w x 2'h/3'h/4'h/5'h/6'h  
 20'w x 2'h/3'h/4'h/5'h/6'h

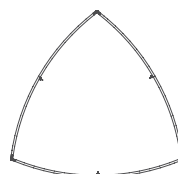

double-sided graphic

PINWHEEL

- 8'w x 2'h/3'h/4'h/5'h/6'h
- 10'w x 2'h/3'h/4'h/5'h/6'h
- 12'w x 2'h/3'h/4'h/5'h/6'h
- 14'w x 2'h/3'h/4'h/5'h/6'h
- 16'w x 2'h/3'h/4'h/5'h/6'h
- 18'w x 2'h/3'h/4'h/5'h/6'h
- 20'w x 2'h/3'h/4'h/5'h/6'h



double-sided graphic

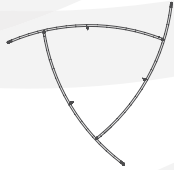

RECTANGLE

- 8'w x 2'h/3'h/4'h/5'h/6'h
- 10'w x 2'h/3'h/4'h/5'h/6'h
- 12'w x 2'h/3'h/4'h/5'h/6'h
- 14'w x 2'h/3'h/4'h/5'h/6'h
- 16'w x 2'h/3'h/4'h/5'h/6'h
- 18'w x 2'h/3'h/4'h/5'h/6'h
- 20'w x 2'h/3'h/4'h/5'h/6'h



double-sided graphic

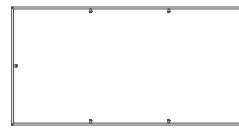

FOOTBALL

- 8'w x 2'h/3'h/4'h/5'h/6'h
- 10'w x 2'h/3'h/4'h/5'h/6'h
- 12'w x 2'h/3'h/4'h/5'h/6'h
- 14'w x 2'h/3'h/4'h/5'h/6'h
- 16'w x 2'h/3'h/4'h/5'h/6'h
- 18'w x 2'h/3'h/4'h/5'h/6'h
- 20'w x 2'h/3'h/4'h/5'h/6'h



double-sided graphic

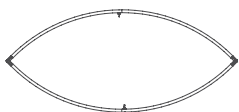

FOUR-SIDED PYRAMID

- 10'w x 5'h
- 12'w x 6'h
- 16'w x 8'h
- 20'w x 10'h

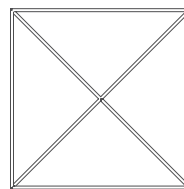

**THREE-SIDED PYRAMID**

10'w x 5'h  
12'w x 6'h  
16'w x 8'h  
20'w x 10'h

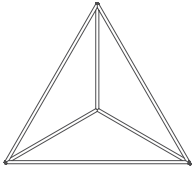

**ROUND FUNNEL**

10'w x 5'h

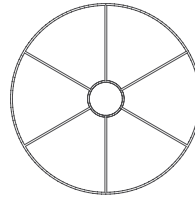

**SQUARE FUNNEL**

10'w x 5'h

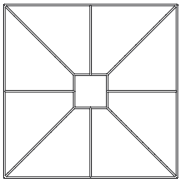

**CONE**

10'w x 5'h  
12'w x 6'h  
16'w x 8'h  
20'w x 10'h

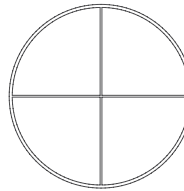

**CURVE**

8'w x 2'h/3'h/4'h/5'h/6'h  
10'w x 2'h/3'h/4'h/5'h/6'h  
12'w x 2'h/3'h/4'h/5'h/6'h  
14'w x 2'h/3'h/4'h/5'h/6'h  
16'w x 2'h/3'h/4'h/5'h/6'h  
18'w x 2'h/3'h/4'h/5'h/6'h  
20'w x 2'h/3'h/4'h/5'h/6'h



**PANEL**

8'w x 2'h/3'h/4'h/5'h/6'h  
10'w x 2'h/3'h/4'h/5'h/6'h  
12'w x 2'h/3'h/4'h/5'h/6'h  
14'w x 2'h/3'h/4'h/5'h/6'h  
16'w x 2'h/3'h/4'h/5'h/6'h  
18'w x 2'h/3'h/4'h/5'h/6'h  
20'w x 2'h/3'h/4'h/5'h/6'h



**DISC**

8' diameter  
10' diameter  
12' diameter  
14' diameter  
16' diameter  
18' diameter  
20' diameter



**S-CURVE**

8'w x 2'h/3'h/4'h/5'h/6'h  
10'w x 2'h/3'h/4'h/5'h/6'h  
12'w x 2'h/3'h/4'h/5'h/6'h  
14'w x 2'h/3'h/4'h/5'h/6'h  
16'w x 2'h/3'h/4'h/5'h/6'h  
18'w x 2'h/3'h/4'h/5'h/6'h  
20'w x 2'h/3'h/4'h/5'h/6'h



## FORMULATE FUNNELS

Whether you are looking for a way to draw attention and captivate your audience at a tradeshow, special event, or in a permanent environment, these FORMulated and tension fabric architectural structures are designed to impress.

Versatile Formulate™ Funnels transform any environment through form, fabric and lighting. Formulate Funnels have an hourglass shape, come in 20ft, 16ft and 12ft heights and have 8ft diameters at the top and 3½ft diameters at the bottom. Funnels feature a heavy-duty, wooden base and silver powder coated truss interior to create a dynamic, towering structure that commands attention. Fabric graphics feature a zipper at the top and a silicone edge at the bottom for easy assembly. Accent LED light not included, but can be incorporated to add a glow within the funnel structures. Custom sizes also available.

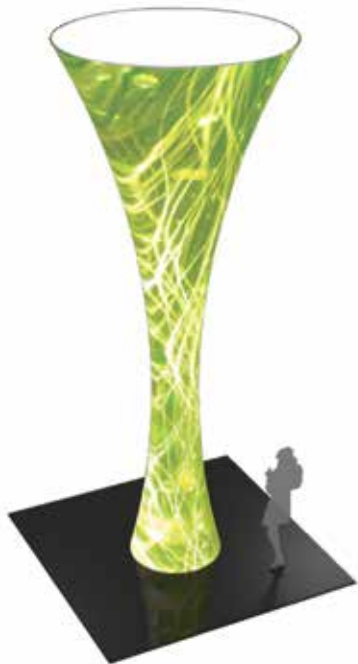

20' FUNNEL  
FUN-01



16' FUNNEL  
FUN-02

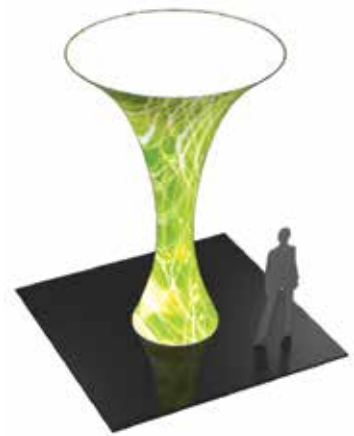

12' FUNNEL  
FUN-03



**FORMULATE TOWERS**

Mix and match the Formulate™ line of towers to add architecture and drama to any event or interior space. Cylinder-shaped and Rectangular-shaped towers come in 12ft, 10ft and 8ft heights and 3ft square/diameters at the tops and bottoms. They combine the latest developments in fabric printed technology with aluminum tube frames to add dimension, décor and sculpture to any event, stage set, tradeshow booth or interior space. Formulate towers accommodate internal LED lighting. Accent LED light not included, but can be incorporated to add a glow within the structures. Custom sizes also available.



12' FOUR  
SIDED TOWER  
COL-01

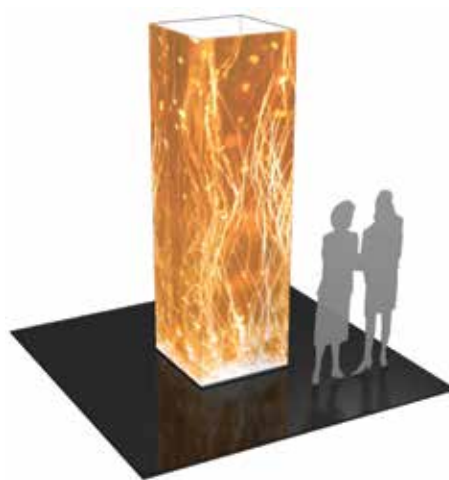

10' FOUR  
SIDED TOWER  
COL-02

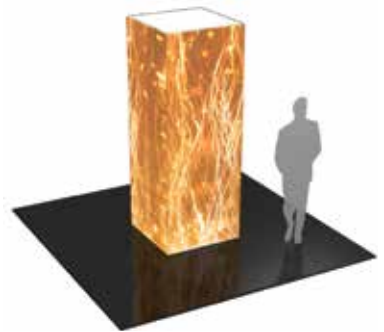

8' FOUR  
SIDED TOWER  
COL-03

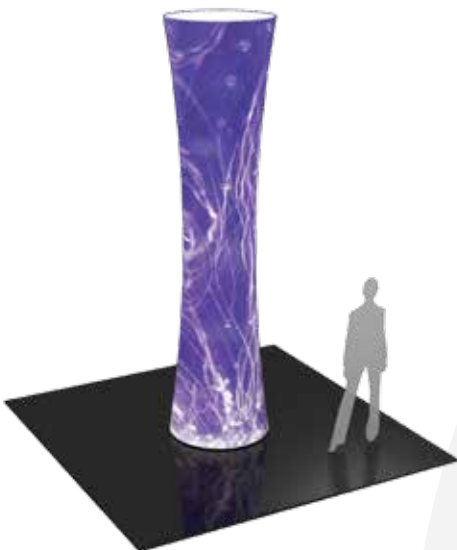

12' CYLINDER TOWER  
CYL-01



10' CYLINDER TOWER  
CYL-02

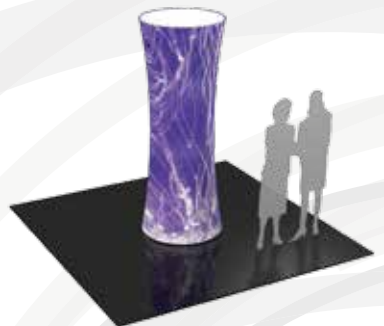

8' CYLINDER TOWER  
CYL-03

## FORMULATE ARCHES

Formulate™ Arches add architecture and design to any event or interior space! Easily create and define a stunning entryway, focal point or stage set at your next tradeshow or event with Formulate Arches.

Formulate Arches combine pillowcase style stretch fabric graphics with 50mm curved aluminum tube frames; these super structures are made in the USA and collapse to a fraction of their size. Custom sizes also available.

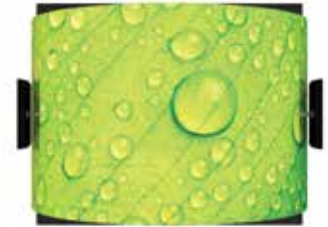

overhead perspective

### ARCH 01 12' ARCH-01

The Formulate™ Arch 01 is 8ft tall and spans 11½ft wide. Two monitor mounts are included, externally facing, adding a bonus opportunity to display messaging and branding. Shown in a 12' space.

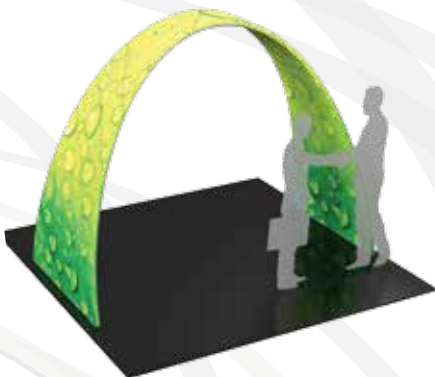

### ARCH 02 10' ARCH-02

The Formulate™ Arch 02 is 7⅔ft tall and spans 9½ft wide. Two bases provide weighted stability and serve as anchors for the fabric structure. Shown in a 10' space.

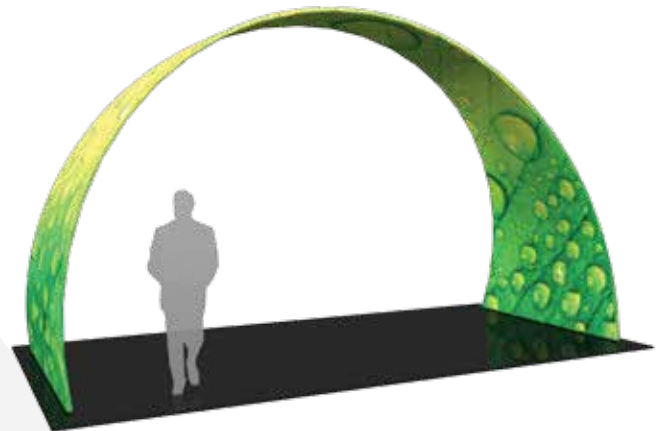

### ARCH 03 20' ARCH-03

The Formulate™ Arch 03 is 11½ft tall and spans 19½ft wide. The Arch fits perfectly in a 20ft by 20ft island space. Shown in a 20' space.

\*monitors not included

**FORMULATE  
CONFERENCE WALLS**

Whether you are looking to create a semi-private meeting area within a tradeshow exhibit, special event, or in an interior environment, FORMulate™ tension fabric conference walls are lightweight, stylish solutions to your meeting space needs.

Ergonomically designed, Formulate C-shaped, Chip-shaped and Serpentine-shaped walls combine the latest developments in fabric printed technology with gently curved 50mm aluminum frames to create private, cozy and stylish conference areas within any space.



**C-SHAPED WALL  
C-WALL**

The Formulate™ C-Wall stands 7ft tall at its highest point and is 7ft 4in diameter. Perfect for a small table and chairs or benches for seating, this mini-conference area combines function and flare to create a stylish, semi-private space.

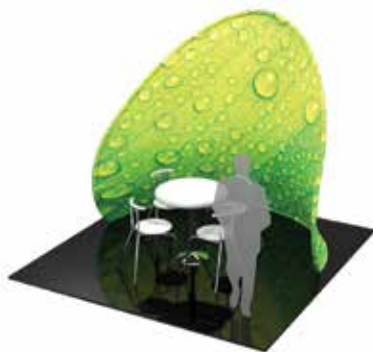

**CHIP-SHAPED WALL  
CHIP-WALL**

The Formulate™ Chip-Shaped Wall is a potato chip shaped structure that stands 8ft tall and is 9ft 3in wide. It is an ideal structure to create a semi-private conference/meeting area or projection wall within a space.

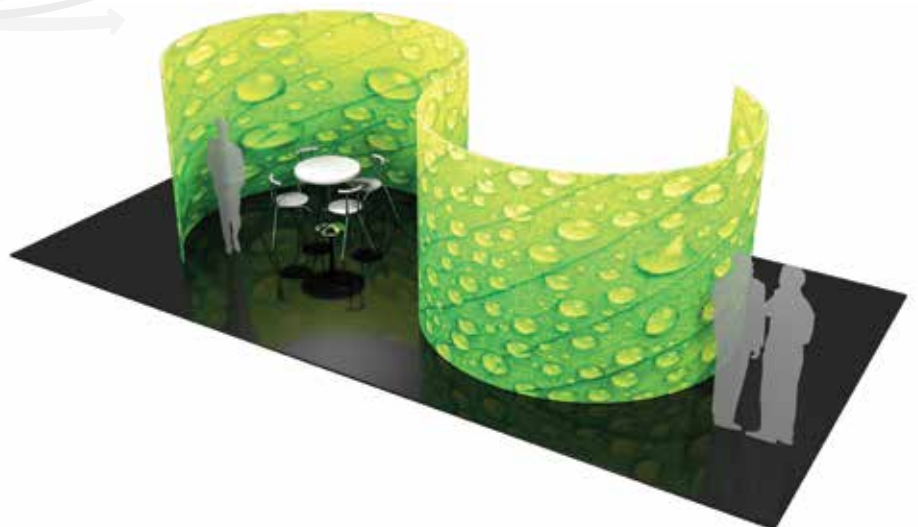

**SERPENTINE WALL  
S-WALL**

The Formulate™ Serpentine shaped wall connects two C-shaped structures to create a multipurpose, Serpentine shaped display. The Serpentine Wall is ideally used as a wall that separates two mini-conference and meeting areas. The Formulate Serpentine Wall is 7ft 7in tall and spans 22ft 10in wide – perfect for use in a large island space.

FORMULATE VIDEO WALLS & ROOMS

Heavy-duty 50mm aluminum frames are coupled with stretch, zipper pillowcase fabric graphics to create flowing, uniquely-shaped Formulate™ curved walls and architectural structures that are ideal for tradeshows, events, corporate environments and interior spaces. With a variety of options, you can mix and match with other Formulate fabric structures to create the ideal display, booth or environment. Custom sizes also available.

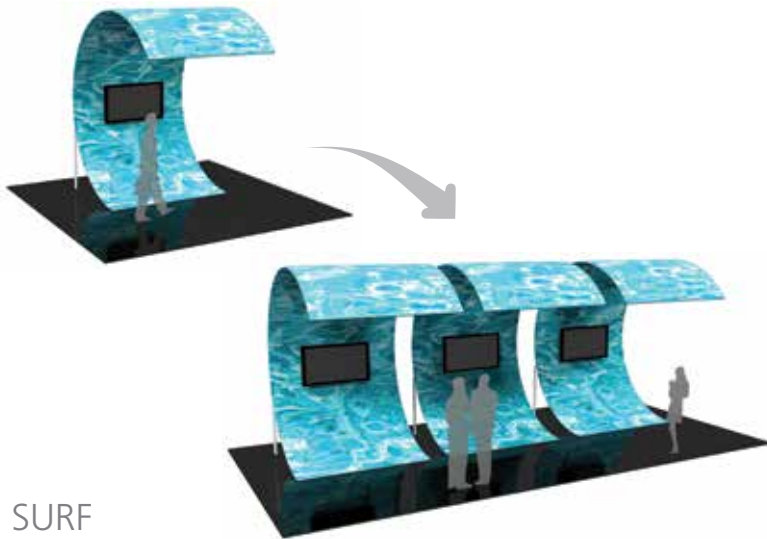

**SURF**  
SURF-WALL

The Formulate™ Surf Wall is a C-shaped multimedia display that stands 11ft 4in tall with a width of 7ft 7in. With an organic, curved shape sustained by supporting legs, and a monitor mount for a monitor/TV, the Surf makes a distinctive statement in any space. Easily add more Surf Walls for an even bigger impact!

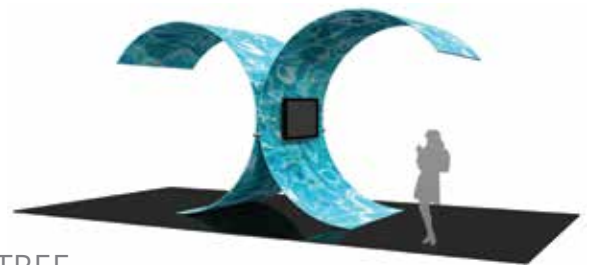

**TREE**  
TREE

Two C-shaped structures are fused together to create a Tree shape with this sculptural, multimedia display. The Formulate™ Tree stands 11ft 4in tall and spans to 20ft 6in wide. The Formulate Tree includes two monitor mounts for use as a multimedia display.

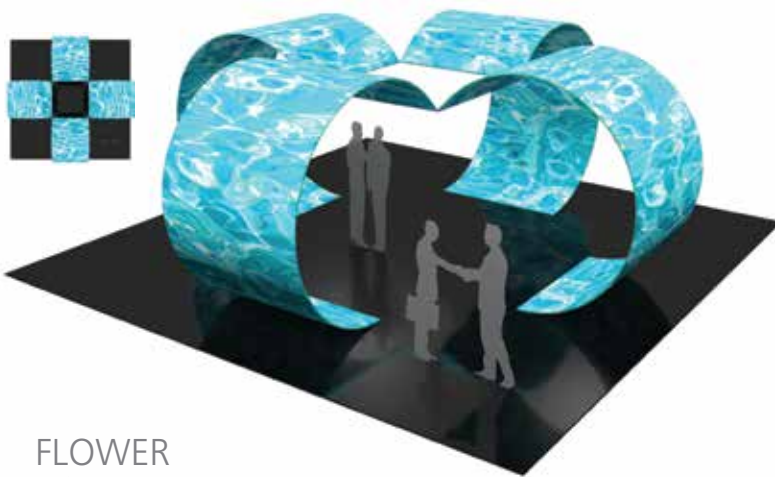

**FLOWER**  
FLOWER-RM

The Formulate™ Flower creates a unique and dynamic space for meetings, demonstrations and more! It connects four C-shaped structures to FORMulate an organic and elegant floral shape. The structure is 27ft 4in square, 11ft 4in tall and fits ideally within a large island space.

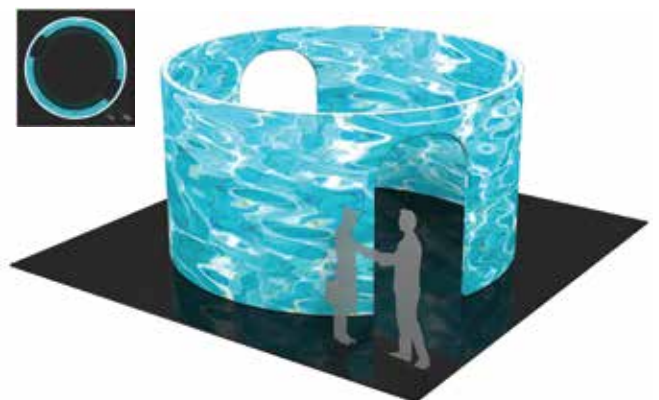

**TREE HOUSE**  
TREEHOUSE-RM

The Formulate™ Tree House is a cylinder-shaped space perfect for meetings, graphical displays, projected presentations, a theater setting and much more. The Tree House is 15ft in diameter, 8ft tall and features two 7ft tall doorways, encouraging traffic flow through the structure.

**NEW**



**COBRA**  
FMLT-ESS-COBRA

36" w x 90" h x 51.43" d  
The Cobra is a single or double-sided fabric banner stand. Simply connect the basic lightweight aluminum tube frame, slip the fabric graphic on and you have a sleekly serpentine-curved banner stand in minutes.

**NEW**



**ENTICE**  
FMLT-ESS-ENTICE-01  
FMLT-ESS-ENTICE-02

41.7" w (at top) - 29.8" w (at bottom) x 102.6" h  
Entice is a double-sided tension fabric display stand that features a clear, acrylic shelf. Entice is offered with a curved or sloped top and allows you to dress up any space with your own graphic. Entice comes with a canvas over-the-shoulder carry bag.



**SHARK FIN**  
SHARK

70" w x 86" h x 18" d  
The Formulate™ Shark Fin is an ideal banner for any indoor or outdoor event. Simply slip the fabric graphic over the frame and you have an instant display.



**FORMULATE FABRIC BANNER**  
FMLT-WV03-01

36" w x 91" h x 30" d  
A sophisticated display for any space, the Formulate™ Vertical Curve fabric banner combines a lightweight aluminum frame with zipper-pillowcase graphic.

**iPAD KIOSK 01**  
TABLET-STD-01

33" w x 84" h x 23" d  
Monitor mount, iPad holder  
Pillowcase fabric graphic



**iPAD KIOSK 02**  
TABLET-STD-02

20.25" w x 85" h x 23.8" d  
iPad holder  
Pillowcase fabric graphic



**iPAD KIOSK 03**  
TABLET-STD-03

20" w x 64.335" h x 15.2" d  
iPad holder  
Pillowcase fabric graphic





# VIBRANT.VERSATILE.VISION. VECTOR FRAME™ TENSION FABRIC

Vector Frame™ backwalls and kits can configure from a banner to a backwall to a full exhibit • Quality crafted and manufactured in the USA, Vector Frame is customizable, reconfigurable with simple graphic changes • Convey new or multiple messages easily • Single and double-sided SEG fabric graphic options make it easy to get a maximum impact



# VECTOR FRAME™

The Vector Frame™ series is a collection of off-the-shelf, extrusion-based, push-fit fabric graphic displays. The Vector Frame line features fabric backwalls/banners, light boxes, table top displays, 10' and 20' exhibit kits, counters and more. In addition, Vector Frame can be customized for completely tailored exhibits and interior display solutions.



Banners & Light Boxes



Backwalls



Essential Kits



Master Kits

## VECTOR FRAME™ MASTER KITS

The innovative, contemporary and clean appearance of the Vector Frame™ Master line of exhibit kits will captivate your audience. Kits feature push-fit fabric graphics, easy-to-assemble extrusion frames, accent lighting, tables, counters, literature accessories, monitor mounts and interior LED edge lighting where indicated. Customized kits are also available.

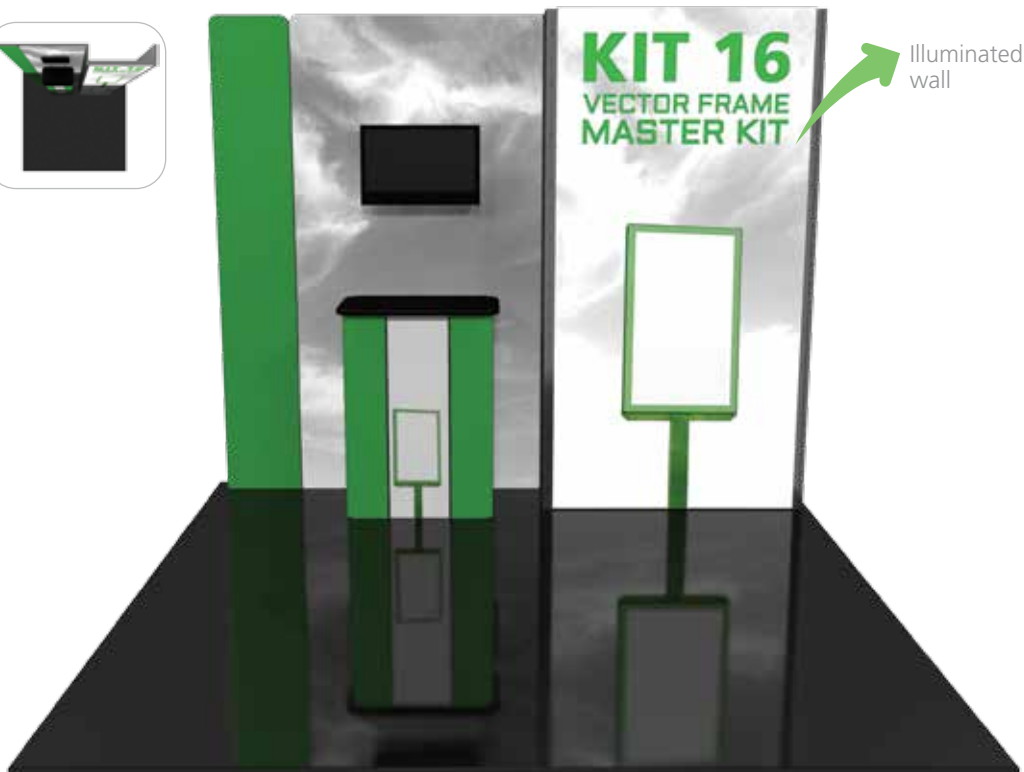

Illuminated wall

10'x10' KIT KIT 16 VF-K-16



easy to apply push-fit fabric graphics



Vector Frame counter tops are available in your choice of four thermoform finishes



silver black mahogany natural

\*monitors not included

# VECTOR FRAME™ MASTER KITS



The innovative, contemporary and clean appearance of the Vector Frame™ line of exhibit kits will captivate your audience. Kits feature push-fit fabric graphics, easy-to-assemble extrusion frames, accent lighting, tables, counters, literature accessories, monitor mounts and interior LED edge lighting where indicated.

VECTOR FRAME 10' MASTER KITS



10'x10' KIT KIT 09 VF-K-09



10'x10' KIT KIT 10 VF-K-10

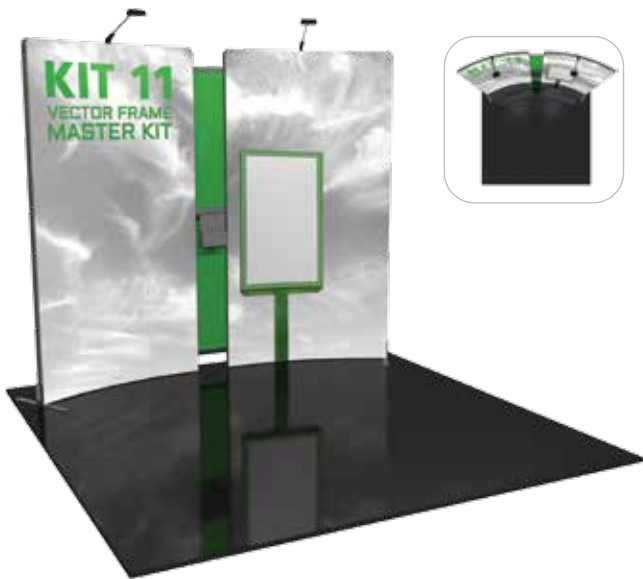

10'x10' KIT KIT 11 VF-K-11



10'x10' KIT KIT 12 VF-K-12



easy to apply push-fit fabric graphics



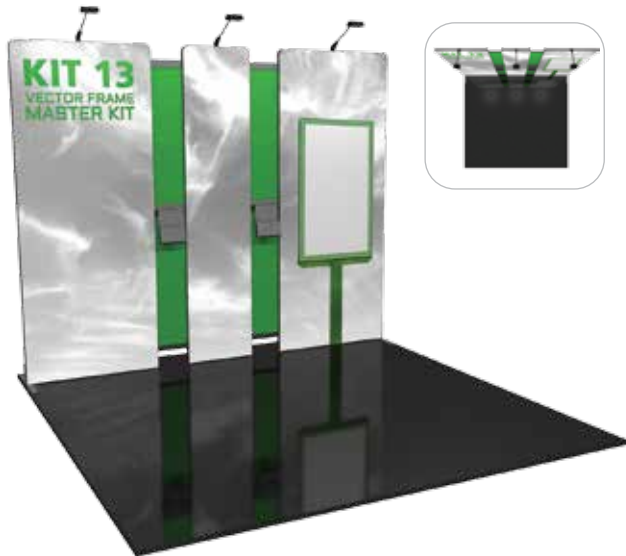

10'x10' KIT **KIT 13**  
VF-K-13



10'x10' KIT **KIT 14**  
VF-K-14



10'x10' KIT **KIT 15**  
VF-K-15



10'x10' KIT **KIT 16**  
VF-K-16



Vector Frame counter tops are available in your choice of four thermoform finishes



silver black mahogany natural



OCH2 & OCE wheeled molded cases included with each kit (page 137-138)

\*monitors not included

# VECTOR FRAME™ MASTER KITS



The innovative, contemporary and clean appearance of the Vector Frame™ line of exhibit kits will captivate your audience. Kits feature push-fit fabric graphics, easy-to-assemble extrusion frames, accent lighting, tables, counters, literature accessories, monitor mounts and interior LED edge lighting where indicated.

VECTOR FRAME 20' MASTER KITS

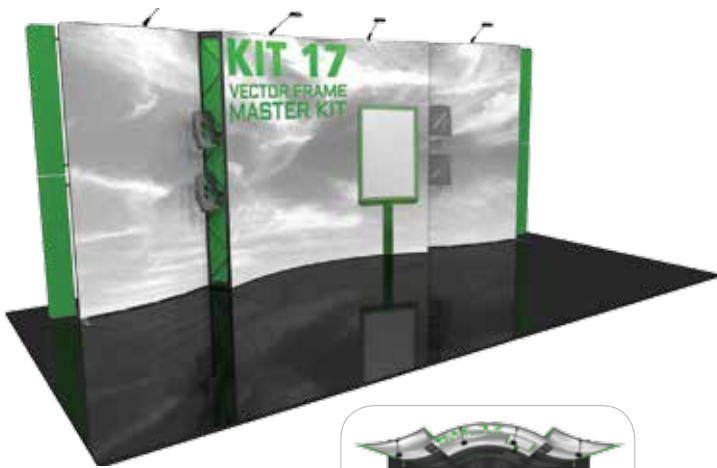

10'x20' KIT KIT 17 VF-K-17

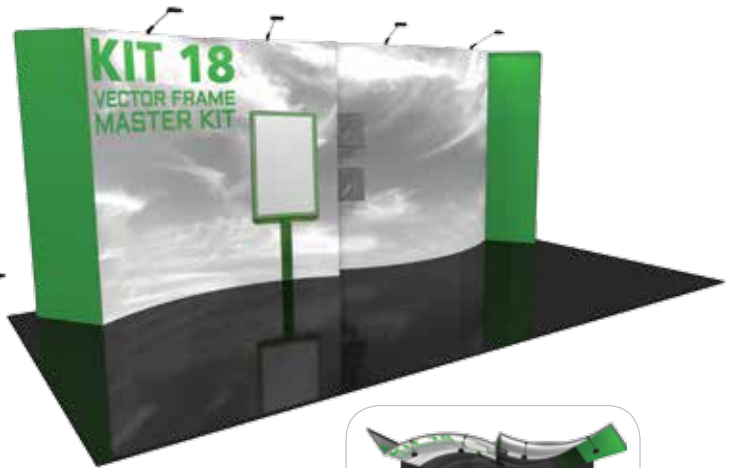
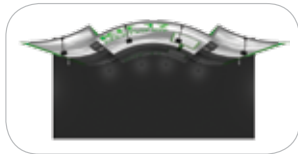

10'x20' KIT KIT 18 VF-K-18

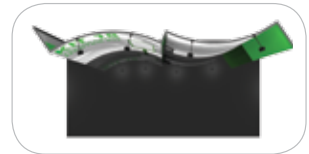

10'x20' KIT KIT 19 VF-K-19

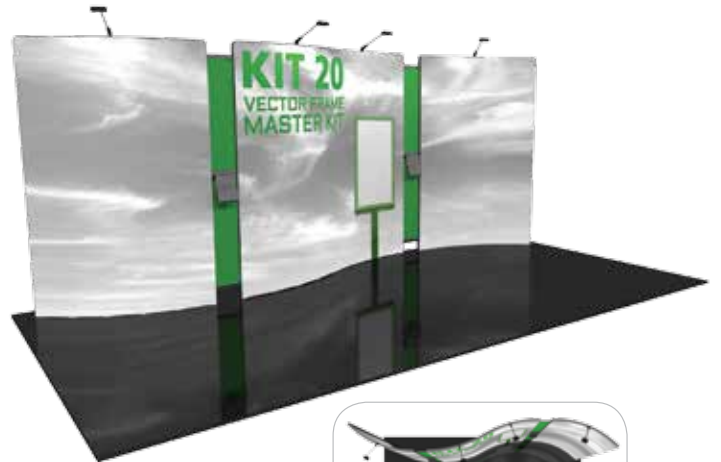

10'x20' KIT KIT 20 VF-K-20



Vector Frame Counter 02 VFC-02



Vector Frame Counter 06 VFC-06



Vector Frame Counter 07 VFC-07



10'x20'  
KIT VF-K-21



10'x20'  
KIT VF-K-22



10'x20'  
KIT VF-K-23



10'x20'  
KIT VF-K-24



easy to apply push-fit fabric graphics

Vector Frame counter tops are available in your choice of four thermoform finishes

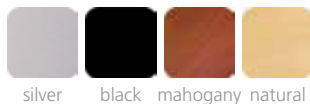

silver black mahogany natural



OCH2 & OCE wheeled molded cases included with each kit (page 137-138)

\*monitors not included

# VECTOR FRAME™ ESSENTIAL KITS



Stand apart from the competition with a clean, sophisticated 10'x10' or 10'x20' Vector Frame™ exhibit kit. These graphic mural kits feature square-corner 50mm extrusion frames and push-fit fabric graphics that cover the entire frame. Vector Frame Standard kits are easy to assemble and disassemble.

VECTOR FRAME 10' ESSENTIAL KITS

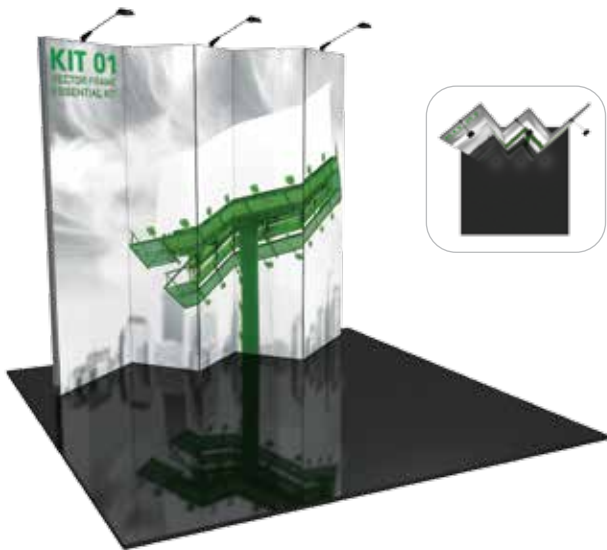

10'x10' KIT **KIT 01**  
VF-K-01



10'x10' KIT **KIT 02**  
VF-K-02

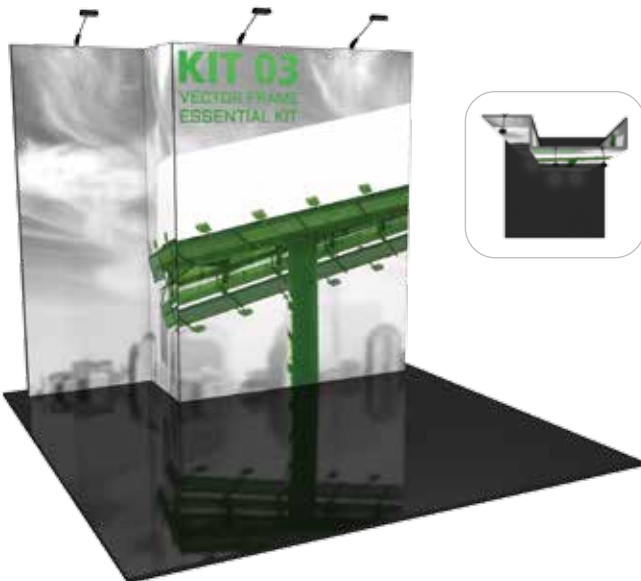

10'x10' KIT **KIT 03**  
VF-K-03



10'x10' KIT **KIT 04**  
VF-K-04



easy to apply push-fit fabric graphics



OCH2 & OCE wheeled molded cases included with each kit (page 137-138)



10'x20' KIT  
KIT 05  
VF-K-05

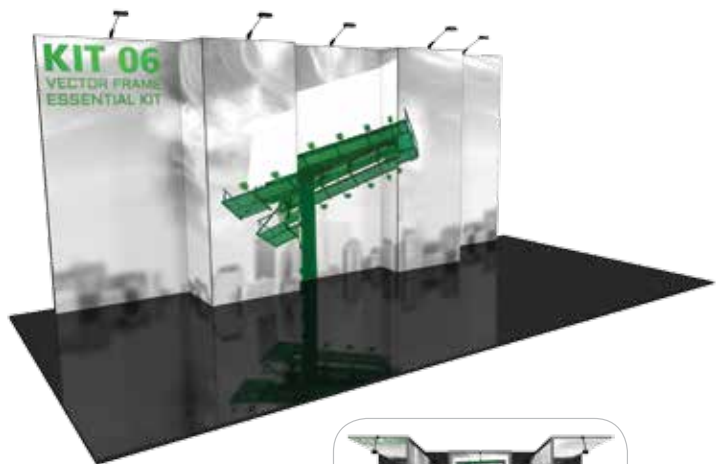
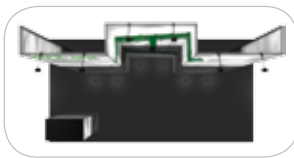

10'x20' KIT  
KIT 06  
VF-K-06

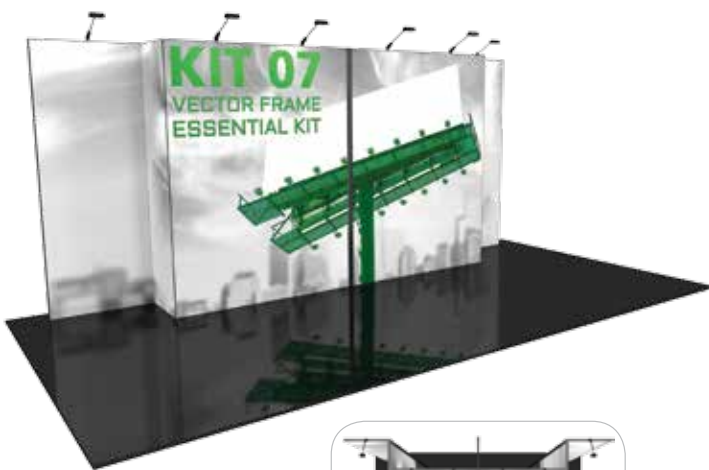

10'x20' KIT  
KIT 07  
VF-K-07



10'x20' KIT  
KIT 08  
VF-K-08



easy to apply push-fit fabric graphics

Vector Frame counter tops are available in your choice of four thermoform finishes



silver black mahogany natural



OCH2 & OCE wheeled molded cases included with each kit (page 137-138)

# VECTOR FRAME™ TABLETOPS



Vector Frame™ Tabletop Kits provide modern and dynamic flare to your marketing message. The silicone edge (SEG) push-fit fabric graphics and extrusion-based displays are simple, lightweight and take minutes to assemble. Units come in a sturdy case. Customized units also available.

VECTOR FRAME TABLETOP KITS

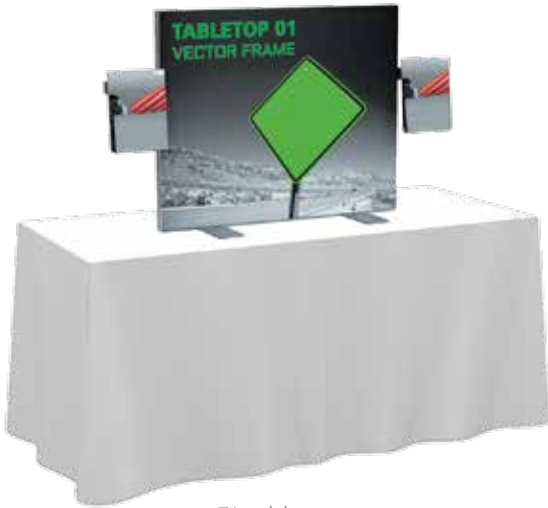

5' tabletop  
footprint dimensions:  
57" w x 31.5" h x 17.72" d  
VF-K-TT-01



5' tabletop  
footprint dimensions:  
61.5" w x 31.5" h x 17.72" d  
VF-K-TT-02



4 1/2' tabletop  
footprint dimensions:  
53.35" w x 39.37" h x 17.72" d  
VF-K-TT-03



8' tabletop  
footprint dimensions:  
96" w x 39.37" h x 17.72" d  
VF-K-TT-04



easy to apply push-fit fabric graphics



OCS  
wheeled molded  
cases included  
with each kit  
(page 137)

NEW



LIFE TIME

# VECTOR FRAME™ COUNTERS

Vector Frame™ counters compliment the Vector Frame series of exhibit kits, but are also ideal for any stand-alone event or display. Vector Frame counters couple simple extrusion-based frames with push-fit fabric graphics or rigid sintra graphics. Tables are available in four colored finishes – silver, black, mahogany and natural. Counters fit in an OCH2 portable shipping case and allow for accessible storage by removing one fabric panel. Custom sizes also available.

Vector Frame counter tops are available in your choice of four thermoform finishes



silver black mahogany natural



Vector Frame Counter 01  
39.37" w x 36.62" h x 22.5" d  
VFC-01



Vector Frame Counter 02  
55.25" w x 40.5" h x 22.75" d  
VFC-02



Vector Frame Counter 03  
38.25" w x 40.5" h x 19.875" d  
VFC-03



Vector Frame Counter 04  
31" w x 40.5" h x 19" d  
VFC-04



Vector Frame Counter 05  
39.5" w x 40.5" h x 23" d  
\*features locking door and rigid sintra graphics  
VFC-05



Vector Frame Counter 06  
42" w x 40.5" h x 21" d  
\*features locking door and rigid sintra graphics  
VFC-06



Vector Frame Counter 07  
46" w x 40.5" h x 23" d  
VFC-07

## VECTOR FRAME™ FABRIC LIGHT BOXES

Vector Frame™ fabric light boxes feature durable 100mm aluminum extrusion frames, push-fit backlit fabric graphics and LED edge lighting. Single and double-sided graphic options are available.

**NEW**

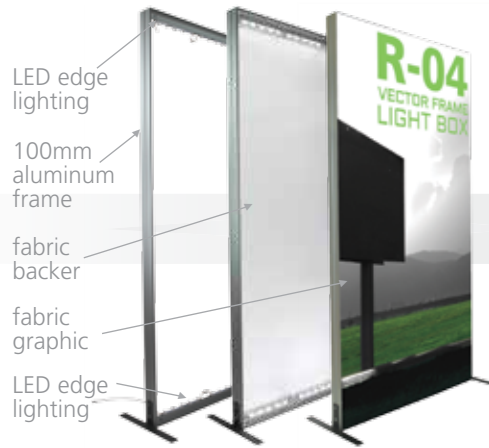

LED lights come adhered to the frame, making set-up as simple as:

1. assembling the frame
2. applying the push-fit graphics
3. plugging in the electrical cord!

04 Rectangle  
VF-LB-R-04  
47" w x 94" h x 19" d  
comes in OCH case

### AVAILABLE SIZES



01 Rectangle  
VF-LB-R-01  
35" w x 47" h x 13" d  
comes in OCE case



02 Rectangle  
VF-LB-R-02  
35" w x 70" h x 13" d  
comes in OCH case



03 Rectangle  
VF-LB-R-03  
47" w x 70" h x 19" d  
comes in OCH case



05 Rectangle  
VF-LB-R-05  
118" w x 94" h x 19" d  
comes in OCH case



01 Square  
VF-LB-S-01  
35" w x 35" h x 13" d  
comes in OCE case



02 Square  
VF-LB-S-02  
47" w x 47" h x 13" d  
comes in OCE case



03 Square  
VF-LB-S-03  
70" w x 70" h x 19" d  
comes in OCH case



04 Square  
VF-LB-S-04  
94" w x 94" h x 19" d  
comes in OCH case

## VECTOR FRAME™ CURVED BANNERS

**NEW**

Vector Frame™ curved banners combine 50mm aluminum extrusion frames with push-fit fabric graphics to create a versatile single and double-sided banner, backwall or interior display. Use as a concave or convex shape.



01 Curved Rectangle  
VF-CR-01  
30" w x 94.5" h x 20" d  
comes in OCL case



02 Curved Rectangle  
VF-CR-02  
51.5" w x 94.5" h x 20" d  
comes in OCL case



03 Curved Rectangle  
VF-CR-03  
61" w x 94.5" h x 20" d  
comes in OCE case



## VECTOR FRAME™ BANNERS

Vector Frame™ banners combine aluminum extrusion frames with push-fit fabric graphics to create a versatile banner, backwall, hanging art or display. Vector Frame banners can be used to display messaging or art in a corporate environment or at a tradeshow and feature single or double-sided graphics.



fits perfect in a 10' space

05 Rectangle  
VF-R-05  
118" w x 94" h x 19" d  
comes in 1 OCL case

### AVAILABLE SIZES



01 Rectangle  
VF-R-01  
35" w x 47" h x 13" d  
comes in 1 OCL case



02 Rectangle  
VF-R-02  
35" w x 70" h x 13" d  
comes in 1 OCS case



03 Rectangle  
VF-R-03  
47" w x 70" h x 19" d  
comes in 1 OCL case



04 Rectangle  
VF-R-04  
47" w x 94" h x 19" d  
comes in 1 OCL case



01 Square  
VF-S-01  
35" w x 35" h x 13" d  
comes in 1 OCS case



02 Square  
VF-S-02  
47" w x 47" h x 13" d  
comes in 1 OCL case



03 Square  
VF-S-03  
70" w x 70" h x 19" d  
comes in 1 OCS case



04 Square  
VF-S-04  
94" w x 94" h x 19" d  
comes in 1 OCL case



### VECTOR FRAME™ WALL BRACKET VF-BRKT-4

- supports any size banner vector frame
- quick and easy to assemble
- turns your vector frame from a portable to a wall display
- customer to provide fasteners
- sold in packs of four



easy to apply push-fit fabric graphics



OCS

OCL



# CREATE.ATTRACT.ENGAGE. **ORBITAL EXPRESS™ TRUSS**

The Orbital Express™ System is quite possibly the easiest Truss • This system has a set number of parts and connectors and requires NO TOOLS for assembly • This versatile system enables you to reconfigure a kit in multiple ways and combinations using the same parts • With Orbital, you can have the impact of a “new look” for every show



# ORBITAL EXPRESS™ TRUSS

The Orbital Express Truss™ System requires NO TOOLS for set up! Installation couldn't be easier; simply twist & lock. The specially designed connectors are simple to use, strong & secure. Our truss kits can be reconfigured in multiple ways using the same parts. Have a different exhibit for each show! We offer more than 60 professionally designed "off the shelf" kits for a variety of booth sizes and configurations. Custom designed configurations are also available.

ORBITAL EXPRESS | 10' X 10' KITS

PLANETARY



**SIRIUS**  
10'x10'  
KIT OR-K-SR1

# ORBITAL EXPRESS™ TRUSS HERCULES KITS

The Hercules line of Orbital Express™ Truss features basic backwalls and kits in a variety of sizes to suit a range of space needs. A benefit to this versatile system is that it enables you to reconfigure kits in multiple ways and combinations using the same parts. Simply add or subtract from any Hercules kit to create a new appearance for every event or tradeshow!

## HERCULES 01

10'x10'  
KIT OR-K-HC01

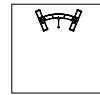

## HERCULES 02

10'x10'  
KIT OR-K-HC02

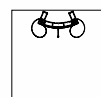

## HERCULES 03

10'x10'  
KIT OR-K-HC03

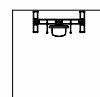

## HERCULES 04

10'x10'  
KIT OR-K-HC04

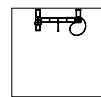

## HERCULES 05

10'x10'  
KIT OR-K-HC05

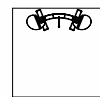

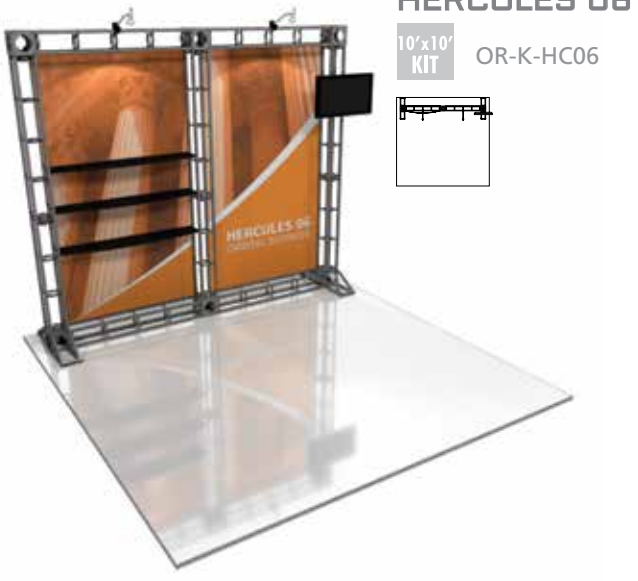

**HERCULES 06**

10'x10' KIT OR-K-HC06

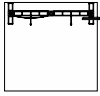

**HERCULES 07**

10'x10' KIT OR-K-HC07

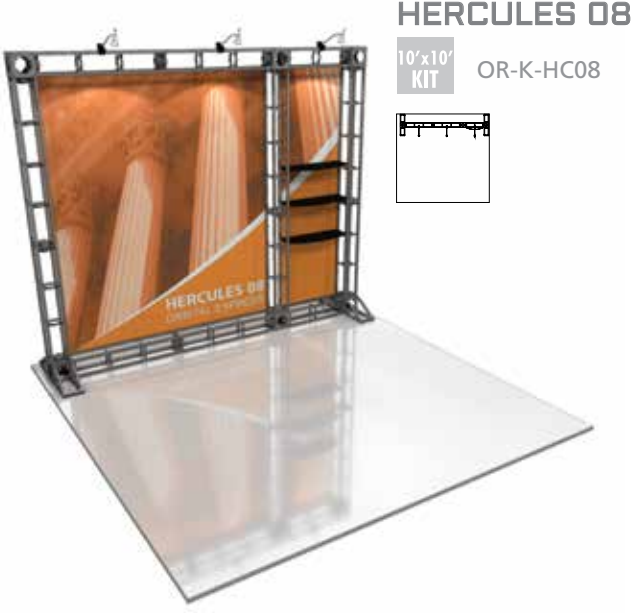

**HERCULES 08**

10'x10' KIT OR-K-HC08

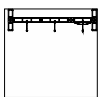

**HERCULES 09**

10'x10' KIT OR-K-HC09



**HERCULES 10**

10'x10' KIT OR-K-HC10

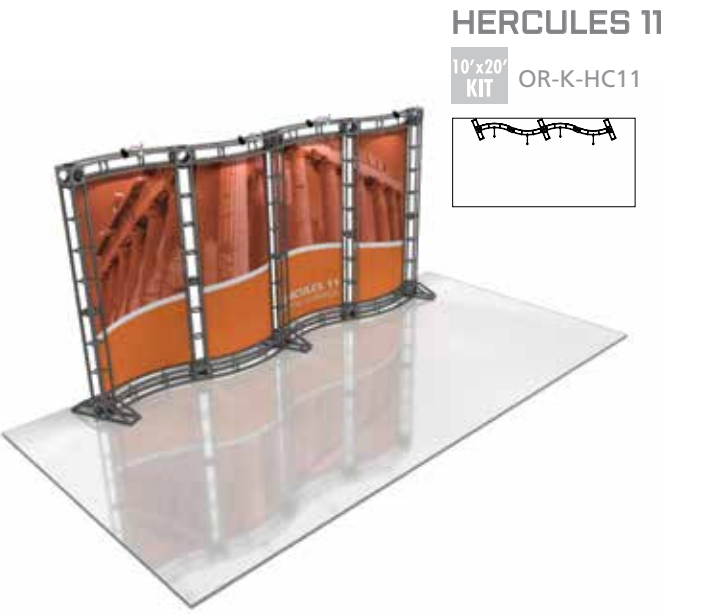
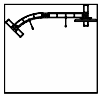

**HERCULES 11**

10'x20' KIT OR-K-HC11

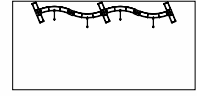

**HERCULES 12**

10'x20'  
KIT

OR-K-HC12

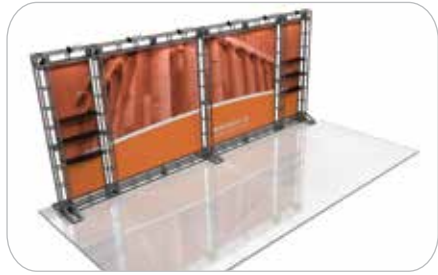
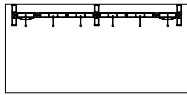

**HERCULES 13**

10'x20'  
KIT

OR-K-HC13

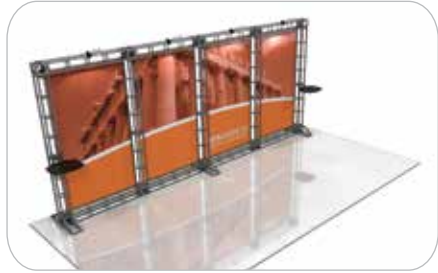
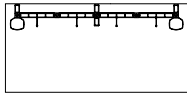

**HERCULES 14**

10'x20'  
KIT

OR-K-HC14

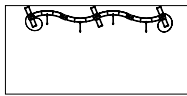

**HERCULES 15**

10'x20'  
KIT

OR-K-HC15

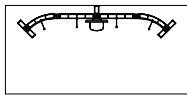

# ORBITAL EXPRESS™ TRUSS PLANETARY KITS

The Planetary line of Orbital Express™ Truss features over 40 professionally designed “off the shelf” kits for a variety of booth sizes and configurations. Each kit comes complete with all the parts, fixtures and fittings you need to create a successful exhibit, including (depending on the kit) low voltage spotlights and adjustable tabletops. A benefit to this versatile system is that it enables you to reconfigure kits in multiple ways and combinations using the same parts. Orbital Express Truss can also be easily configured to fit your custom needs!

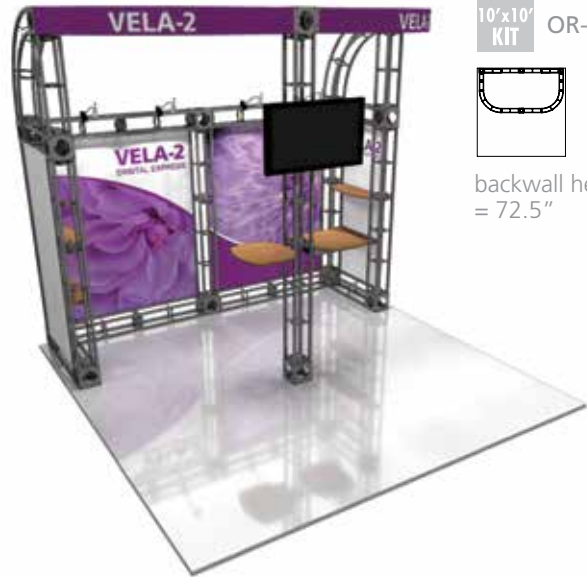

**VELA-2**  
10'x10' KIT OR-K-VL1-2



backwall height = 72.5"

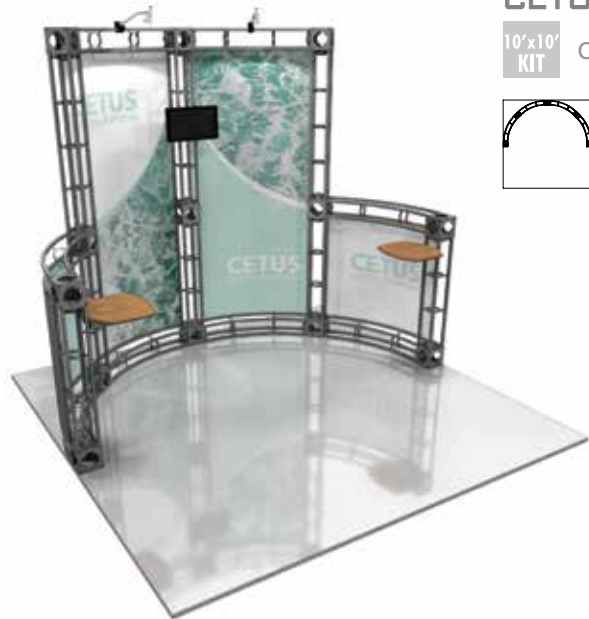

**CETUS**  
10'x10' KIT OR-K-CT1

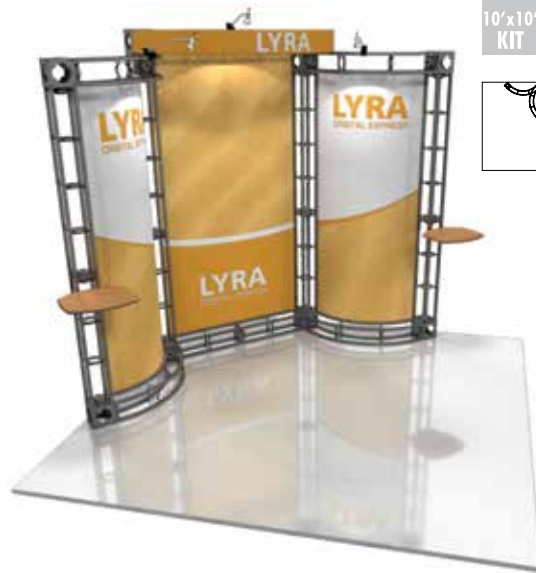

**LYRA**  
10'x10' KIT OR-K-LY2 corner kit



**CARINA**  
10'x10' KIT OR-K-CR1

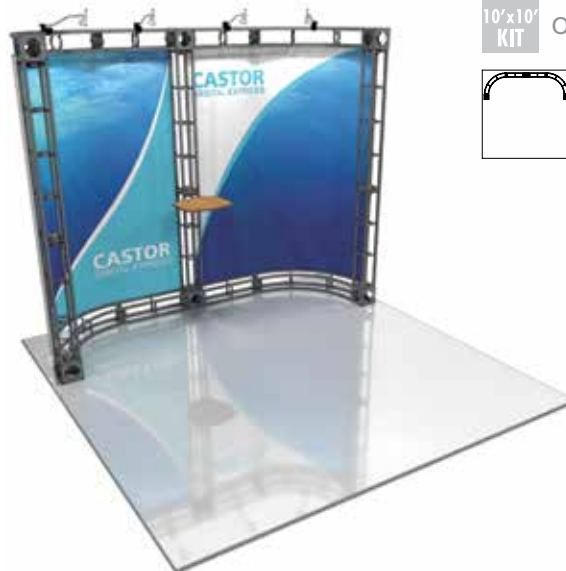

**CASTOR**  
10'x10' KIT OR-K-CS1



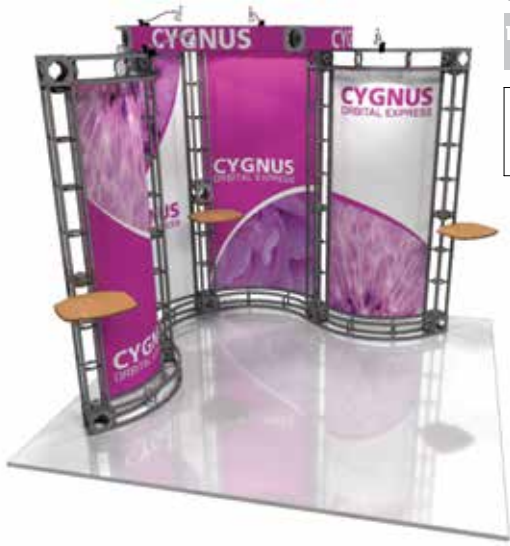

**CYGNUS**  
10'x10' KIT OR-K-SYG2  
corner kit

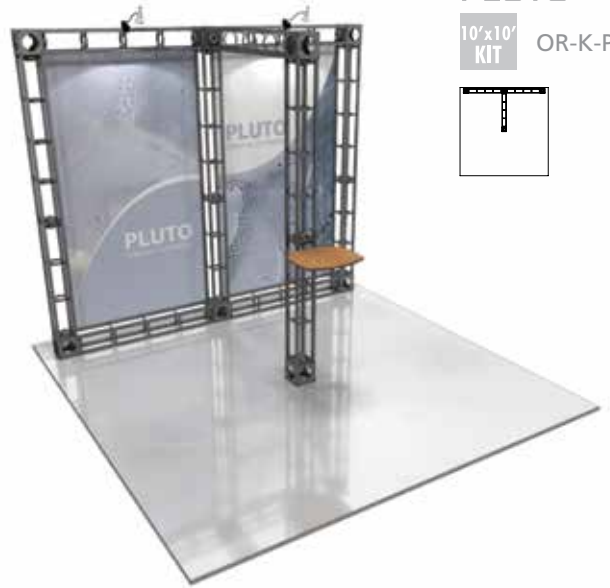

**PLUTO**  
10'x10' KIT OR-K-PL1

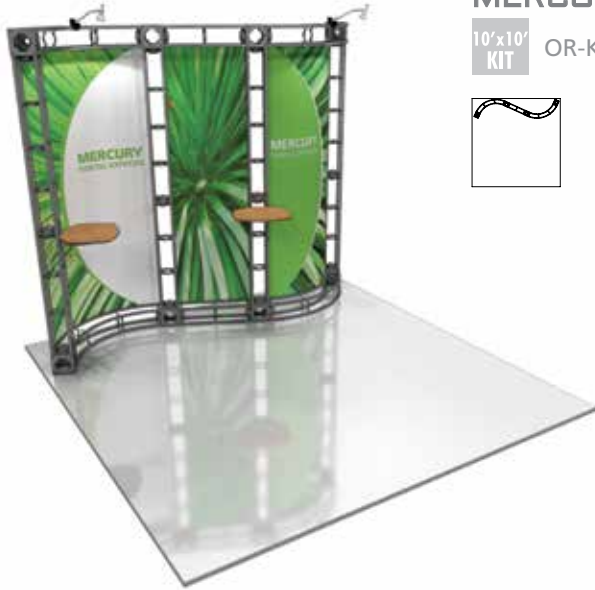
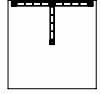

**MERCURY**  
10'x10' KIT OR-K-ME1

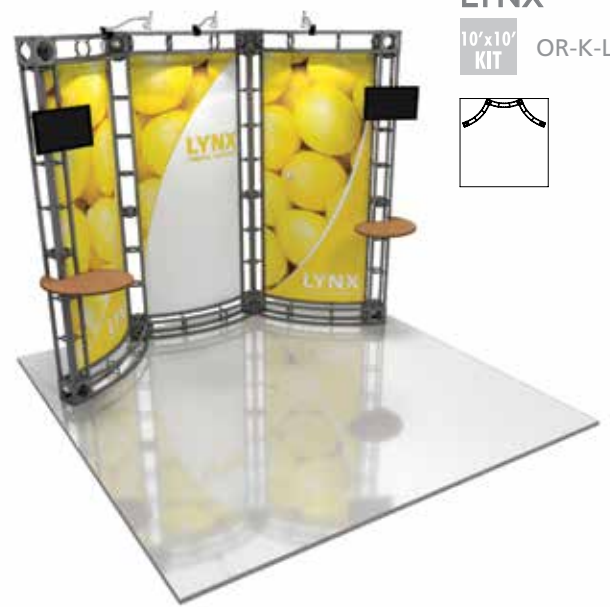

**LYNX**  
10'x10' KIT OR-K-LX1

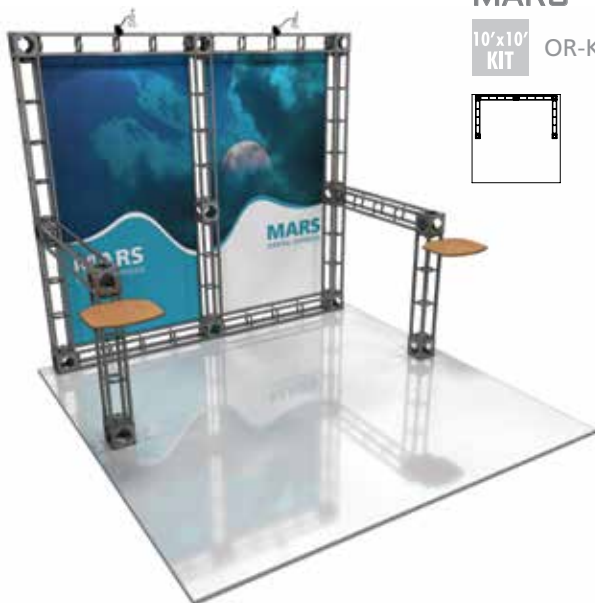
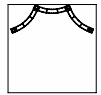

**MARS**  
10'x10' KIT OR-K-MR1



**ARA**  
10'x10' KIT OR-K-AA1

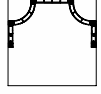



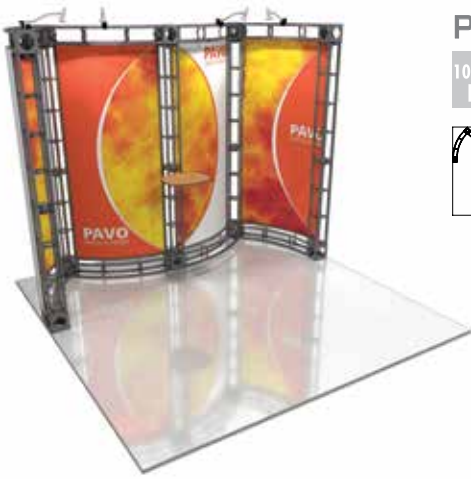

**PAVO**  
10'x10'  
KIT OR-K-PA1

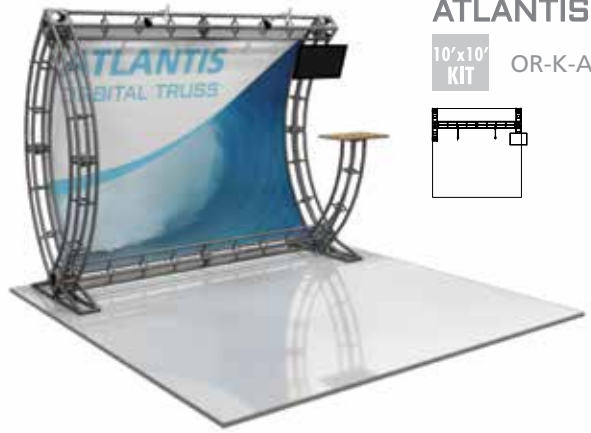

**ATLANTIS**  
10'x10'  
KIT OR-K-ATL3



**CEPHEUS-2**

10'x20'  
KIT OR-K-CE1-2

backwall height = 72.5"

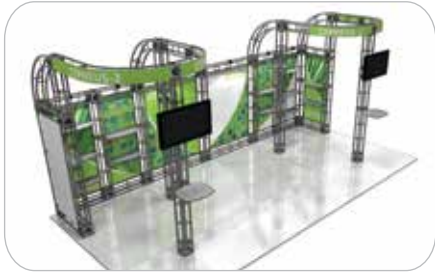
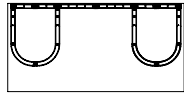

**THETA**

10'x20'  
KIT OR-K-TH1



**PICTOR**

10'x20'  
KIT OR-K-PC1

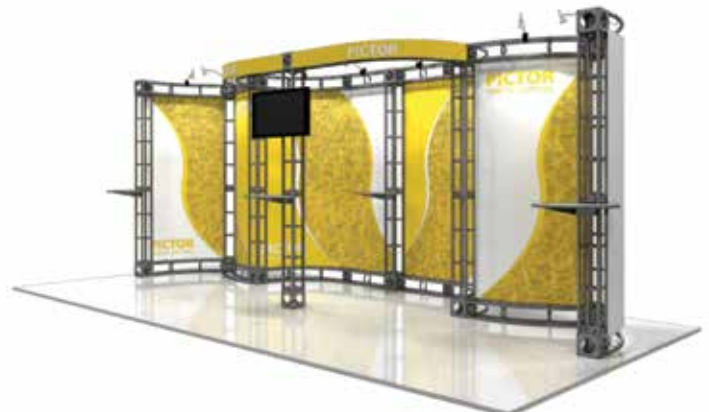
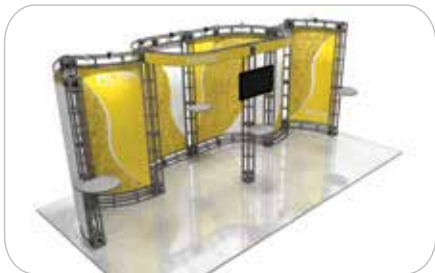
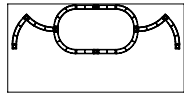

**INDUS**

10'x20'  
KIT OR-K-IN1

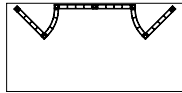

**ANTARES**

10'x20'  
KIT OR-K-AT1

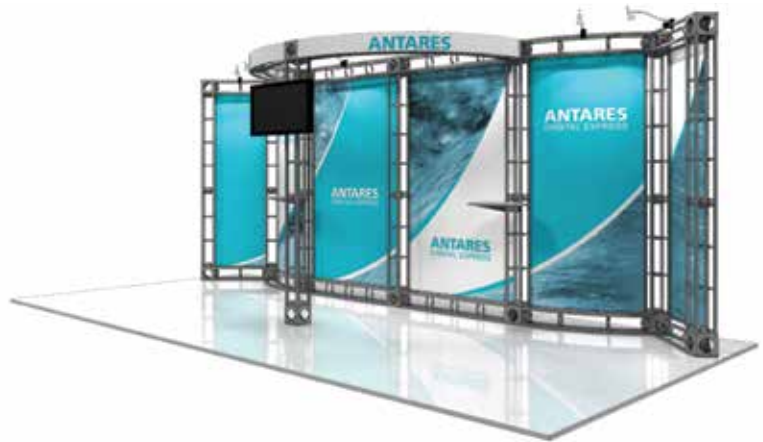
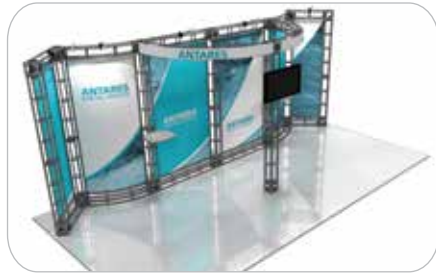
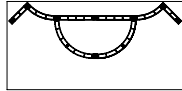

**SATURN**

10'x20'  
KIT OR-K-SA1

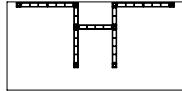

**ELECTRA**

10'x20'  
KIT OR-K-EL1

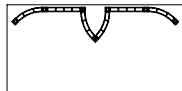

# PHOENIX

10'x20'  
KIT OR-K-PX1

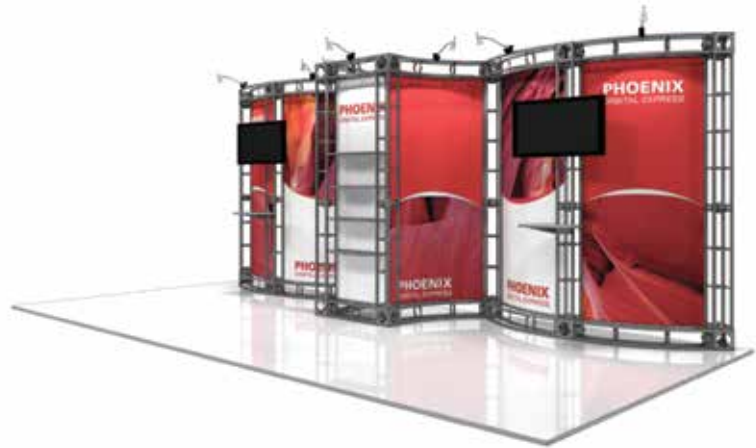
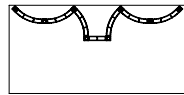

# POLARIS

10'x20'  
KIT OR-K-PR1

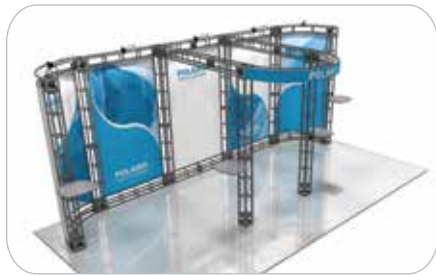
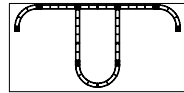

# OMICRON

10'x20'  
KIT OR-K-OM1

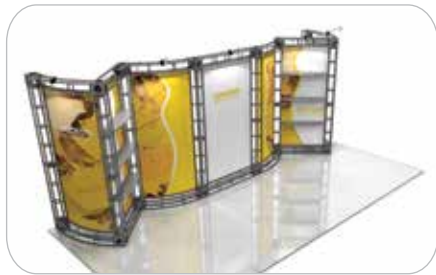
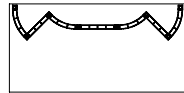

# ANDROMEDA

10'x20'  
KIT OR-K-AD1

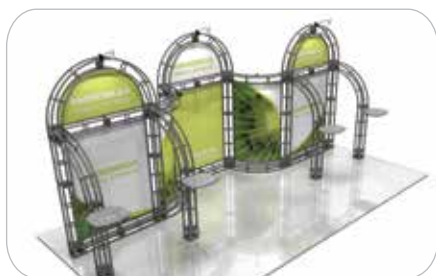
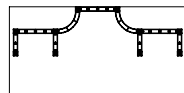

### ARCTURUS

10' x 20' KIT OR-K-AR1

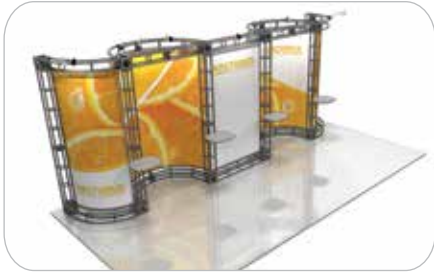
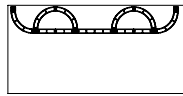

### VENUS

10' x 20' KIT OR-K-VE1

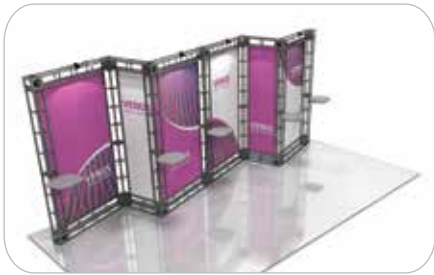
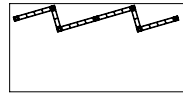

### MAGELLAN

10' x 20' KIT OR-K-MG1

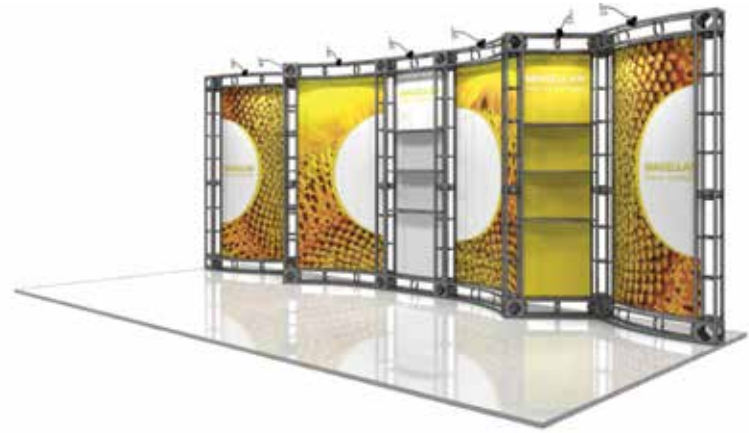
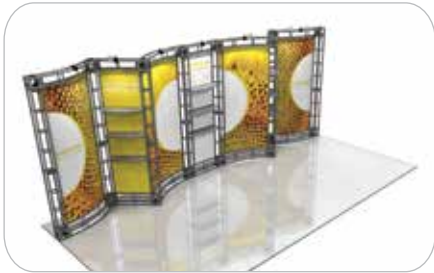
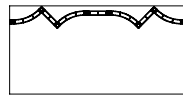

### HYDRUS

10' x 20' KIT OR-K-HD1

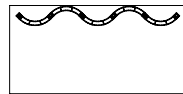

# LEO

20'x20'  
KIT

OR-K-LE1

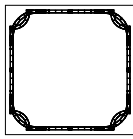

# DORADO

20'x20'  
KIT

OR-K-DO1

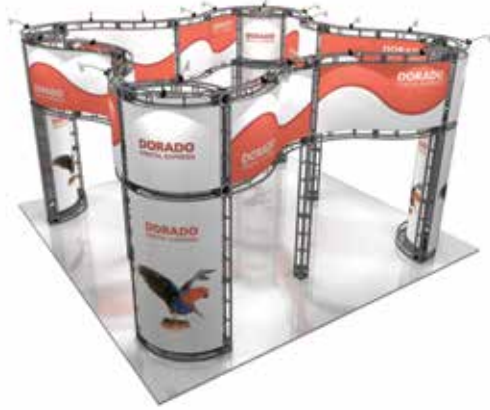
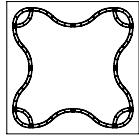

# CORVUS

20'x20'  
KIT

OR-K-CV1

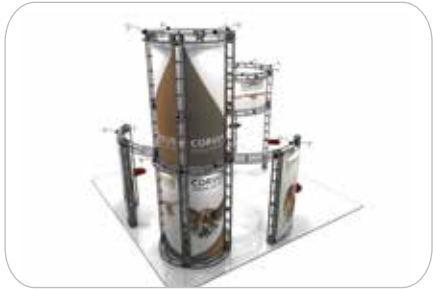
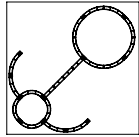

# CENTAURUS

20'x20'  
KIT

OR-K-CN1

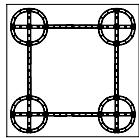

### NEPTUNE

20'x20'  
KIT OR-K-NP1

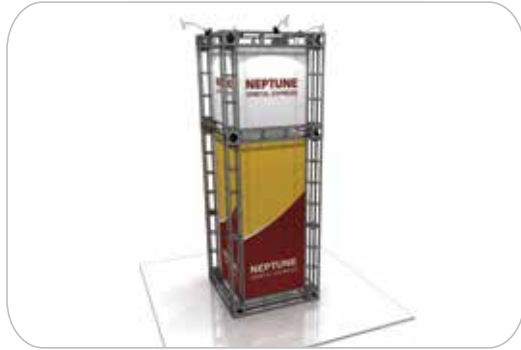
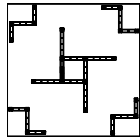

tower also sold seperately: OR-K-NET

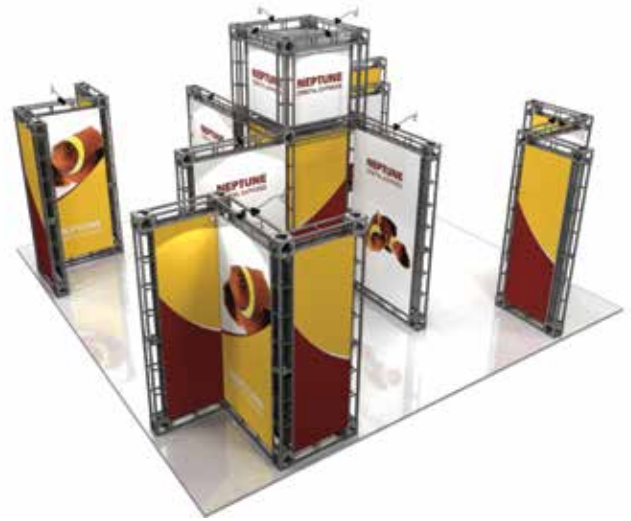

### TUCANA

20'x20'  
KIT OR-K-TU1

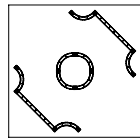

tower also sold seperately: OR-K-TUT



### ORION

20'x20'  
KIT OR-K-OR1

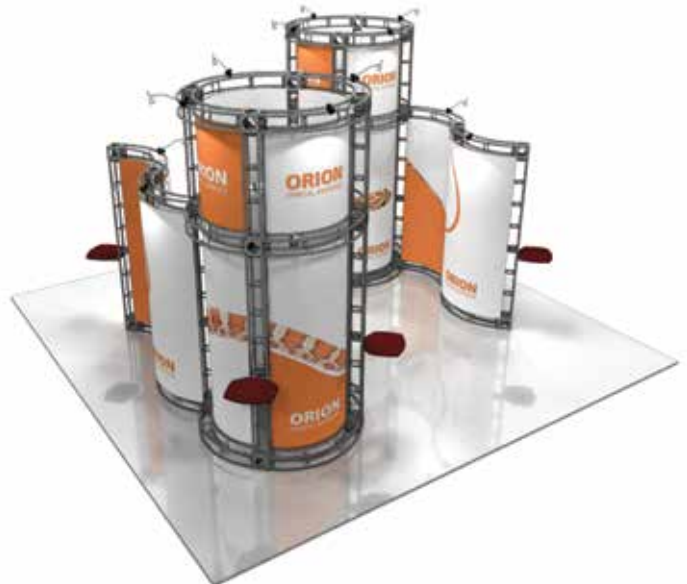
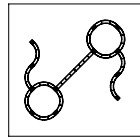

# VEGA

20'x20'  
KIT OR-K-VG1

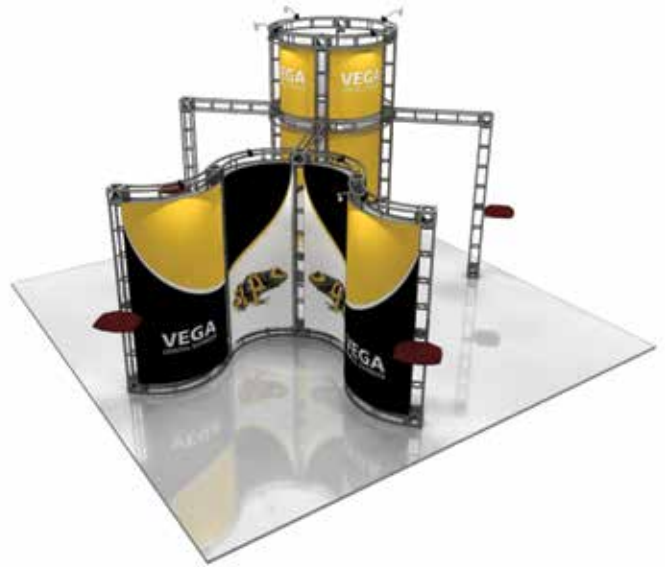
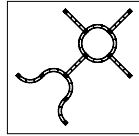

# ALTAIR

20'x20'  
KIT OR-K-AL1

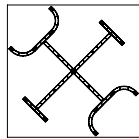

# CANIS

20'x20'  
KIT OR-K-CA1

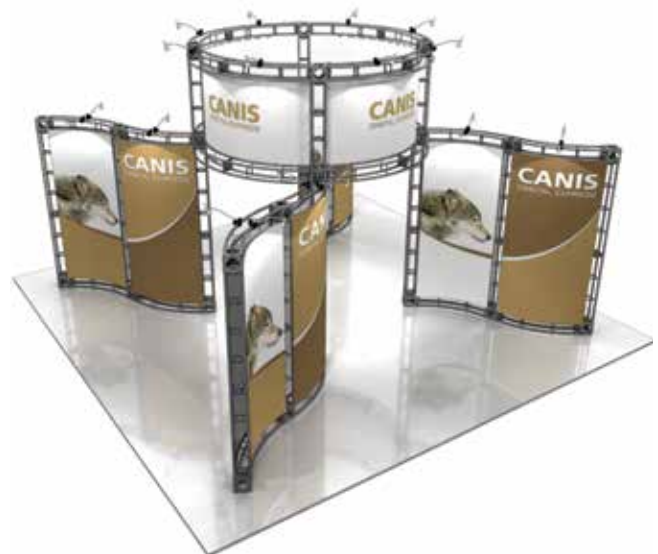
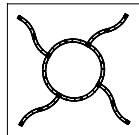

**DRACO**

20'x20'  
KIT OR-K-DR1

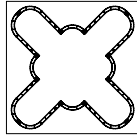

**JUPITER**

20'x20'  
KIT OR-K-JP1

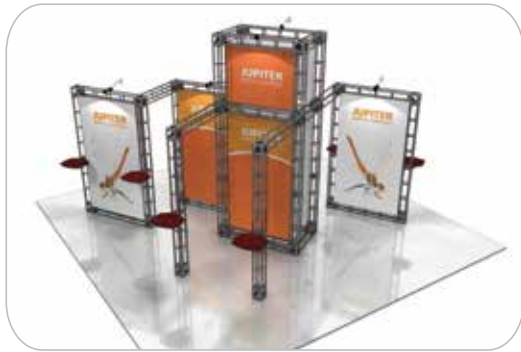
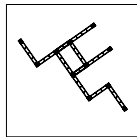

**CASSIOPEIA**

20'x20'  
KIT OR-K-CP1

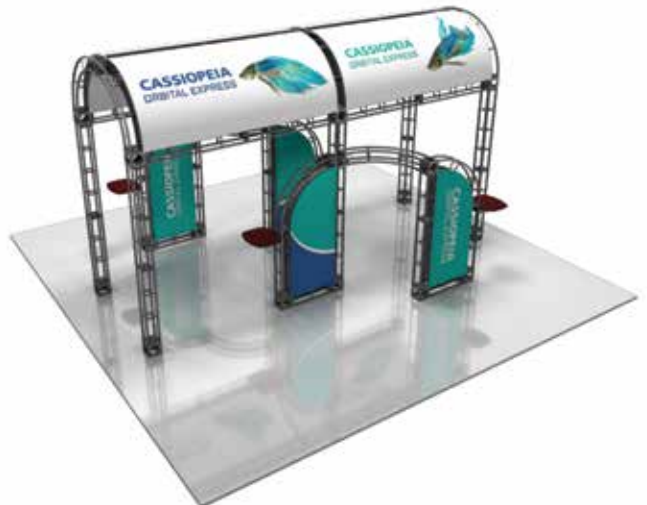
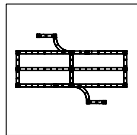





# ORBITAL TRUSS KIOSKS COUNTERS & PODIUMS

Truss counter tops are available in your choice of four thermoform finishes

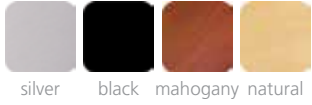

silver black mahogany natural

Truss Counters and Podiums have several attractive designs to choose from with a sleek plex top as an available option. Choose from four tabletop colors. Graphic options are also available for Truss Counters. No tools needed for assembly.



**RECTANGLE**  
standard: OR-TC01  
with plex stand-off and  
internal shelf: OR-TC01-P



**OVAL**  
standard: OR-TC02  
with plex stand-off and  
internal shelf: OR-TC02-P



**RACETRACK**  
standard: OR-TC03  
with plex stand-off and  
internal shelf: OR-TC03-P



**CURVE**  
standard: OR-TC04  
with plex stand-off and  
internal shelf: OR-TC04-P



**CIRCLE**  
standard: OR-P01  
with plex stand-off:  
OR-P01-P



**TEARDROP**  
standard: OR-P02  
with plex stand-off:  
OR-P02-P



**EYE**  
standard: OR-P03  
with plex stand-off:  
OR-P03-P



**RACETRACK**  
standard: OR-P04  
with plex stand-off:  
OR-P04-P



**SQUARE**  
standard: OR-P05  
with plex stand-off:  
OR-P05-P



All Orbital Truss accessories come with a five year limited warranty

# ORBITAL TRUSS ACCESSORIES



Accessories such as tabletops, shelves, literature holders and monitor mounts add functionality and options to your display. Truss tabletops and shelves come in four tabletop colors. No tools needed for assembly.

## LAMINATE TABLETOPS

NATURAL



standard: OR-TBL-WD  
right facing: OR-TBL2-R-WD  
left facing: OR-TBL-L-WD

MAHOGANY



standard: OR-TBL-DW  
right facing: OR-TBL2-R-DW  
left facing: OR-TBL2-L-DW

SILVER



standard: OR-TBL-S  
right facing: OR-TBL2-R-S  
left facing: OR-TBL2-L-S

BLACK



standard: OR-TBL-B  
right facing: OR-TBL2-R-B  
left facing: OR-TBL2-L-B

## INTERNAL SHELVING

- available in all 4 finishes
- 24" straight span, 36" straight span, and 46" straight span shelves available
- 45° curved and 90° curved shelves

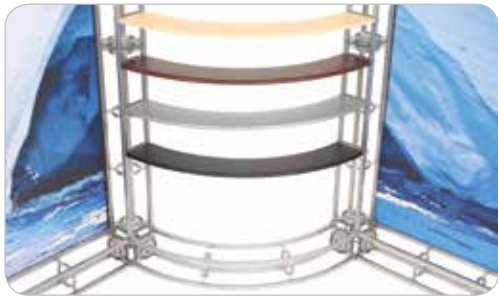

## LIT RACK

OR-STG

- 10 pocket clamp on literature rack
- note: rack may not fit into the standard kit packaging solution/ molded case

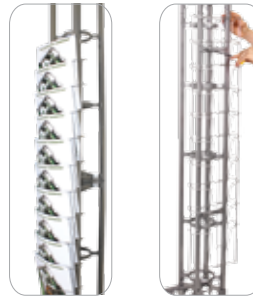

## OPTI MOUNTS



**OPTI-MOUNT 1**  
OR-LCD1-B

13" - 27" LCD  
max weight = 50 lbs



**OPTI-MOUNT 2**  
OR-LCD2-B

26" - 42" LCD  
max weight = 100 lbs



**OPTI-MOUNT 3**  
OR-LCD3-B

32" - 70" LCD  
max weight = 150 lbs



All Orbital Truss accessories come with a five year limited warranty



# ORBITAL TRUSS KIOSKS

Orbital Express™ Truss Kiosks are the perfect way to display media and/or literature at any trade show, event, retail or corporate space. Kiosks complement the Orbital Truss Express line of 10', 20' and 20' by 20' displays. Monitors not included. Kiosk table tops and bases available in choice of four thermoform finishes.

Truss counter tops are available in your choice of four thermoform finishes

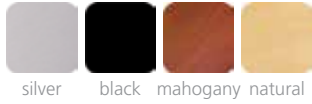

ORBITAL EXPRESS | KIOSKS

## ORBITAL KIOSK 01 OR-KIOSK-01

- 30" w x 73.75" h x 20" d
- supports 23" monitor\*, max weight = 30 lbs
- rigid graphic = 12" w x 47.25" h x .25" d
- approximate weight = 70 lbs



## ORBITAL KIOSK 02 OR-KIOSK-02

- 40" w x 73.75" h x 28.25" d
- supports 70" monitor\*, max weight = 150 lbs
- shelf is adjustable
- approximate weight = 210 lbs



## ORBITAL KIOSK 03 OR-KIOSK-03

- 20" w x 48" h x 20" d
- holds up to 20 pieces of literature
- approximate weight = 40 lbs



## ORBITAL KIOSK 04 OR-KIOSK-04

- 30" w x 48" h x 20" d
- holds up to 20 pieces of literature and 2 iPads (2nd, 3rd & 4th generation)
- approximate weight = 55 lbs



## ORBITAL KIOSK 05 OR-KIOSK-05

- 30" w x 68" h x 24" d
- supports 23" monitor\*, max weight = 50 lbs
- holds up to 10 pieces of literature
- approximate weight = 75 lbs



## ORBITAL KIOSK 06 OR-KIOSK-06

- 24" w x 56" h x 34" d
- supports 23" monitor\*, max weight = 50 lbs
- table is 20" w x 14" d
- approximate weight = 75 lbs



\*monitors not included  
All Orbital Truss accessories come with a five year limited warranty



# ELEGANT.INTELLEGENENT.DRAMATIC. **LINEAR™ DISPLAY SYSTEMS**

Linear™ 10ft and 20ft display systems couple heavy-duty extrusion-based frames with Velcro-applied fabric graphics to create a customized look • Provides the benefit of an off-the-shelf solution with a custom appearance • Headers, wings, table accents, literature racks, monitor mounts and counters are just some of the Linear line features that can make a Linear exhibit unique



# LINEAR™ PRO

Linear™ Pro Kits provide a modern, slick and stylish appearance. The extrusion based exhibits feature **velcro-applied fabric graphics**. Headers and wings available in UV printed graphics or frosted plex. Canopy is available in solid stock black, silver or white. Kits come with a fabric graphic canopy, two lights and ship in durable storage cases. Options include LCD monitor mounts, tables, counters, literature pockets and larger freight cases. Customized units also available.



**PRO 22**  
10'x10' KIT LN-K-3P-22



**PRO 25**  
10'x10' KIT LN-K-3P-25



**PRO 26**  
10'x20' KIT LN-K-3P-26



**PRO 27**  
10'x20' KIT LN-K-3P-27



## LINEAR™ COUNTER LN-TBL-SA-RCT

- counter features open back
- 3 graphic panels to display custom graphics
- quick & easy to assemble, tool included
- fits in an OCH shipping and transport case
- aluminum design is sturdy and stable
- available in all four laminate finishes

Linear counter tops are available in your choice of four thermoform finishes





## ADAPTABLE.FUNCTIONAL.PERFORMANCE. **FOLDING DISPLAY PANELS**

Premium portable folding panels provide a professional appearance without the fuss • Our variety of portable folding panels are superbly crafted with seamless panels made of ultra-light core material • Covered on both sides with polyester fabric, which come in a plethora of color choices and options • Use the Velcro-friendly panels as a way to feature your message or add optional detachable graphics

# HERO™ DISPLAY PANELS

Hero™ panel displays are durable premium exhibit panel kits that feature the convenience of folding panels with elegant, seamless panel construction. Hero kits are available in a variety of fabric colors and feature concealed hinges with unique 2" radius curved ends to lend a polished appearance.



fits in an OCH case (case not included, see page 138)



shown with optional graphics  
HERO H16

3'11" HIGH

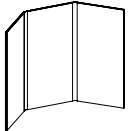

HERO H02-1  
tabletop display

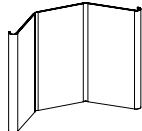

HERO H02-2  
tabletop display with curved end caps



HERO H03  
tabletop display with backlit header

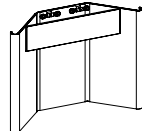

HERO H04  
tabletop display with backlit header and curved end caps

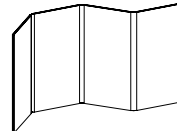

HERO H05  
tabletop display

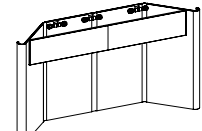

HERO H08  
tabletop display with backlit header and curved end caps

7'10" HIGH

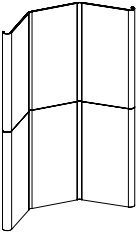

HERO H09  
full height exhibit with curved end caps

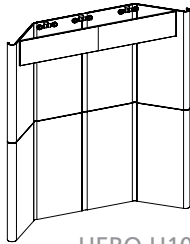

HERO H10  
full height exhibit with curved end caps and backlit header

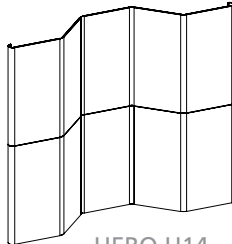

HERO H14  
full height exhibit with curved end caps

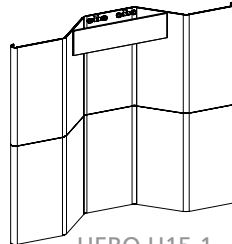

HERO H15-1  
full height exhibit with curved end caps & backlit header

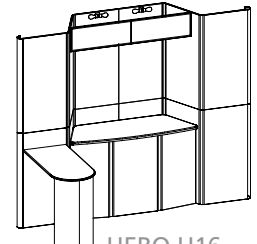

HERO H16  
10' full height exhibit kit with curved end caps, backlit header & peninsula

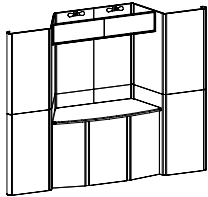

HERO H17  
10' full height exhibit kit with curved end caps & backlit header

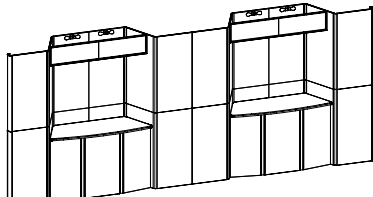

HERO H18  
20' full height exhibit kit with curved end caps & backlit header

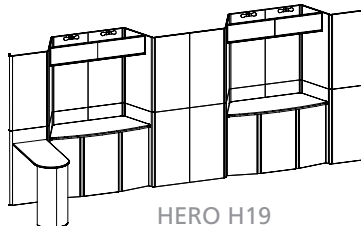

HERO H19  
20' full height exhibit kit with curved end caps, backlit header & one peninsula

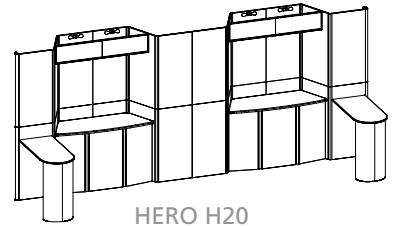

HERO H20  
20' full height exhibit kit with curved end caps, backlit header & two peninsulas

## FABRIC CHOICES

All Horizon & Hero display systems are available with printed graphic murals or "velcro-friendly" fabric panels of your choice. Actual fabric color may vary slightly.

regal - smooth exhibit & display fabric



premier - ribbed exhibit & display fabric



FOLDING DISPLAY PANELS

# VOYAGER™ FOLDING PANELS

The Voyager™ has been specially developed as a briefcase style tabletop display and is a great choice for promotions on the go. It has a rigid, thermo formed ABS exterior and a black, Velcro compatible fabric interior. Detachable graphics allow for easy message changes! Headers shown are an additional option. Extra graphics can be stored in the display case and packed away for easy storage.



FOLDING DISPLAY PANELS

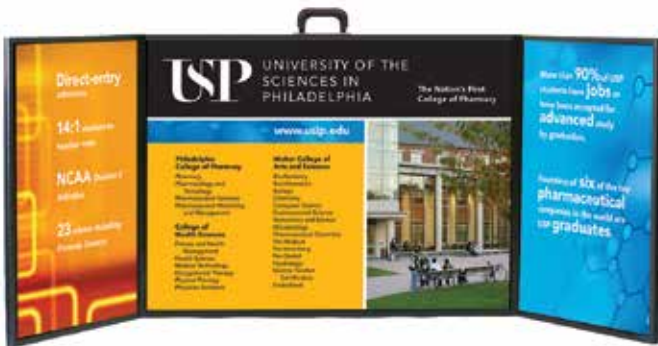

**WEIGHS** 5 LBS **VY 1**

Voyager Mini kit (small)  
open dimensions: 48" w x 18" h  
closed dimensions: 24" w x 18" h



**WEIGHS** 6.5 LBS **VY 2**

Voyager Maxi kit (medium)  
open dimensions: 48" w x 24" h  
closed dimensions: 24" w x 24" h

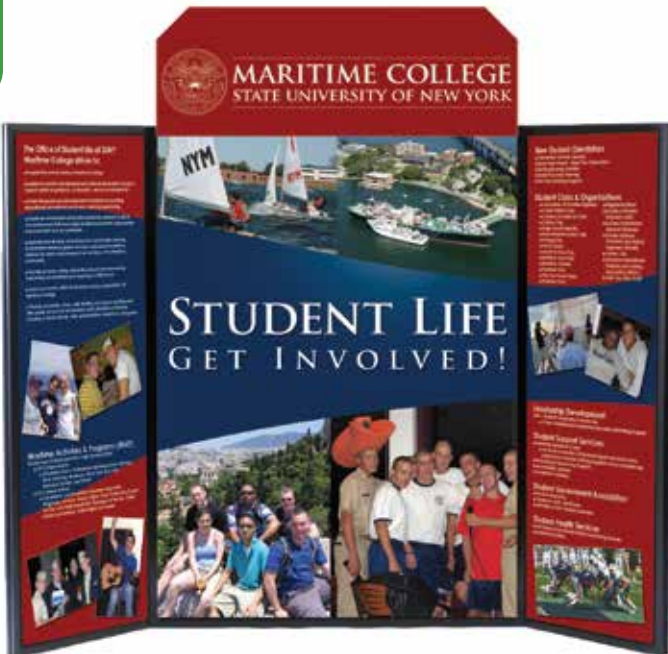

**WEIGHS** 8.25 LBS **VY 3**

Voyager Mega kit (large)  
open dimensions: 48" w x 32" h  
closed dimensions: 24" w x 32" h



**WEIGHS** 8.25 LBS **VY 4**

Voyager Supreme kit (x-large)  
open dimensions: 64" w x 24" h  
closed dimensions: 32" w x 24" h





**WEIGHS  
TO LBS** VY 5

Voyager Monster kit (xx-large)  
open dimensions: 64" w x 32" h  
closed dimensions: 32" w x 32" h



## VOYAGER CARRY BAG



- Voyager Mini bag: VY-1-BG
- Voyager Maxi bag: VY-2-BG
- Voyager Mega bag: VY-3-BG
- Voyager Supreme bag: VY-4-BG
- Voyager Monster bag: VY-5-BG



## CUSTOMIZE

Brand the exterior of your Voyager to match your company and/or product colors to maximize your marketing efforts. Minimum 12 units, call for details.



## HORIZON™ DISPLAY PANELS

- main panel sizes approximately = 24" w x 36" h
- custom sized panel displays are available
- shown with optional detachable graphics
- available in a variety of fabric color options shown below



shown with premium printed table throw (page 16)



**WEIGHS** Horizon 6  
22 LBS HZ-6



**WEIGHS** Horizon 3  
12 LBS HZ-TT-S



**WEIGHS** Horizon 5  
13.5 LBS HZ-TT-M



**WEIGHS** Horizon 8  
31 LBS HZ-8

### FABRIC CHOICES

All Horizon & Hero display systems are available with printed graphic murals or "velcro-friendly" fabric panels of your choice. Actual fabric color may vary slightly.

regal - smooth exhibit & display fabric



premier - ribbed exhibit & display fabric

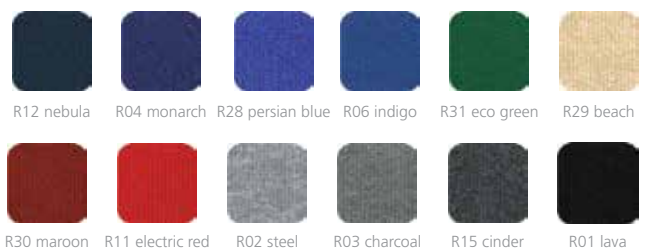



# FINAL.FUNDAMENTAL.FINESSE. **ACCENTS & ACCESSORIES**

Portable counters and kiosks provide ample storage and style to complement our vast array of 8ft, 10ft and 20ft exhibit kits and displays • Accent lighting kits and solutions help stage a powerful, impactful presence that you desire • Portable transit and shipping cases are designed to protect your exhibit investment • From miniature banner stands and literature racks to poster frames and bag dispensers, a variety of display additions and accessories are at your fingertips

# LINEAR™ KIOSKS

Linear™ Kiosks provide unique design elements for a custom look. Aluminum construction coupled with rigid graphic infill panels make these kiosks durable and long lasting.



each Linear kiosk comes with an OCH2 case (page 138)



**LINEAR KIOSK 01**  
LN-K-01

- 54.4" w x 99" h x 23.25" d
- monitor\* mount
- fabric canopy
- approximate weight: 125 lbs



**LINEAR KIOSK 02**  
LN-K-02

- 47.25" w x 96.85" h x 23.25" d
- monitor\* mount
- fabric canopy
- approximate weight: 130 lbs



**LINEAR KIOSK 03**  
LN-K-03

- 47.33" w x 96.85" h x 23.25" d
- fabric canopy
- approximate weight: 115 lbs



**LINEAR KIOSK 04**  
LN-K-04

- 63" w x 96.85" h x 30" d
- 50 watt spotlight
- approximate weight: 90 lbs



## LINEAR™ KIOSKS

Linear™ Monitor Kiosks add function and flare to any space. Extrusion based construction coupled with your choice of rigid graphic infill panels or frosted plex panels make these kiosks sturdy and versatile.

Linear kiosk counter tops are available in your choice of four thermoform finishes

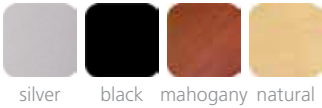

silver black mahogany natural



### LINEAR KIOSK 05 LN-K-05

- 25.38" w x 72.25" h x 18.5" d
- monitor\* mount
- approximate weight: 30 lbs



### LINEAR KIOSK 06 LN-K-06

- 25.38" w x 72.25" h x 18.5" d
- monitor\* mount
- approximate weight: 27 lbs



### LINEAR KIOSK 07 LN-K-07

- 24" w x 86" h x 21" d
- monitor\* mount
- approximate weight: 49 lbs



### LINEAR KIOSK 08 LN-K-08

- 23.5" w x 86" h x 17.75" d
- monitor\* mount
- approximate weight: 46 lbs



\*monitor not included

## FREESTANDING IPAD STANDS

The Freestanding iPad Stand is a smart, lightweight and portable holder used to display the iPad 2nd, 3rd or 4th generations. It can be positioned in either portrait or landscape configurations. Security screws, allen key and bolts make the unit both durable and theft resistant. For extra security, the base can also be bolted to the floor.



PAD12-02A-BLACK

PAD12-02A-SILVER

PAD12-02A-WHITE



Portrait view



Landscape view



Back

## TENSION FABRIC IPAD STANDS

Are you looking to incorporate ipads into your display or environment? Sleekly-designed free standing iPad stands and kiosks make it easy to encourage interactivity, present information and engage your customers in any space. Stands feature stretch fabric graphics.



**IPAD STAND 01**  
TABLET-STD-01

- 30" w x 84" h x 23" d
- monitor\* mount, ipad holder
- pillowcase fabric graphic

**IPAD STAND 02**  
TABLET-STD-02

- 20.25" w x 85" h x 23.8" d
- ipad holder
- pillowcase fabric graphic

**IPAD STAND 03**  
TABLET-STD-03

- 20" w x 64.335" h x 15.2" d
- ipad holder
- pillowcase fabric graphic

\*monitor not included



## TENSION FABRIC COUNTERS

Add modern flare to your trade show exhibit, event or POP display with Formulate™ and Symphony™ fabric counters. With a variety of options to choose from, mix and match to create the ideal display or reception set up.

### FORMULATE™ COUNTERS

Formulate™ counters couple lightweight hardware with state-of-the-art printed stretch silicone edge fabric graphics (SEG) to create funky and functional reception stands. Countertops have built in channels for LED bead lighting to create a soft glow.



**PILLAR**  
W-01-C

**HALF MOON**  
W-02-C

**ELLIPSE**  
W-03-C

**BULLET**  
W-04-C

**OVAL**  
W-05-C

### SYMPHONY™ COUNTERS

Symphony™ counters provide a unique, sleek design that lends an attractive element to any trade show or POP display. Symphony counters combine extrusion-based hardware with state-of-the-art PRINTED or SOLID COLOR stretch fabric silicone edge fabric graphics (SEG).



**OVAL**  
SYM-OV

**RECTANGLE**  
SYM-RCT

**BULLET**  
SYM-BLLT

**OVAL DOUBLE GRAND**  
SYM-OV-DBL-GRND

**3 QUAD KIT**  
SYM-QD-3

tension fabric counter tops are available in your choice of finishes



silver black mahogany natural

counter stretch skirts are available in custom printed options as well as the following colors:



amethyst ruby sapphire emerald silver jet

## VECTOR FRAME™ COUNTERS

Vector Frame™ Counters compliment the Vector Frame series of exhibit kits, but are also ideal for any stand-alone event or display. Vector Frame counters couple simple extrusion-based frames with push-fit fabric graphics or rigid sintra graphics. Tables are available in four colored finishes – silver, black, mahogany and natural. Counters fit in an OCH2 portable shipping case and allow for accessible storage by removing one fabric panel. Custom sizes also available.



Vector Frame counter tops are available in your choice of four thermoform finishes

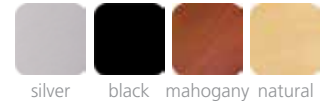

Vector Frame Counter 01  
39.37" w x 36.62" h x 22.5" d  
VFC-01



Vector Frame Counter 02  
55.25" w x 40.5" h x 22.75" d  
VFC-02



Vector Frame Counter 03  
38.25" w x 40.5" h x 19.875" d  
VFC-03



Vector Frame Counter 04  
31" w x 40.5" h x 19" d  
VFC-04



Vector Frame Counter 05  
39.5" w x 40.5" h x 23" d  
\*features locking door and rigid sintra graphics  
VFC-05



Vector Frame Counter 06  
42" w x 40.5" h x 21" d  
\*features locking door and rigid sintra graphics  
VFC-06



Vector Frame Counter 07  
46" w x 40.5" h x 23" d  
VFC-07





## LINEAR™ BOLD COUNTERS

Dress up your space with sophisticated and functional counters. Counter tops are available in four thermoform finishes – silver, black, mahogany and natural. Printed graphic panels create the base of the counter. Comes standard with locking cabinet door. Custom counter top colors are available.

Linear counter tops are available in your choice of four thermoform finishes

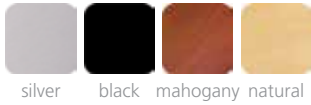

### LINEAR™ COUNTER LN-TBL-SA-RCT

- counter features open back
- 3 graphic panels to display custom graphics
- quick & easy to assemble, tool included
- fits in an OCH shipping and transport case
- aluminum design is sturdy and stable
- available in all four laminate finishes

## HOPUP™ COUNTER

HOP-CT-2

- NEW and IMPROVED collapsible display counter
- taller and easier to assemble
- includes clear internal shelf
- 41.75" w x 39.69" h x 14.25" d
- top available in four laminate finish options



Hopup counter tops are available in your choice of four thermoform finishes



## CAMPAIGN

CP-B2

- counter dimensions not including canopy
- 32" w x 34.5" h x 18.5" d
- quick assembly
- strong & easy to clean plastic parts



## MONITOR KIOSK

VB-MK-01

- medium monitor\* bracket
- max weight = 50 lbs
- comes with 1 OCH2 case
- \*monitor not included



OCH2 wheeled molded cases included with each kit (page 138)



**ZEDUP 1**

black: ZD-1-B  
silver: ZD-1-S

- 6 pocket rack
- can be stored or shipped loaded with literature



hard case upgrade:  
black: ZD-1HC-B  
silver: ZD-1HC-S



**ZEDUP LITE**

silver: ZD-LITE

- 6 pocket rack
- collapsible
- lightweight version of the ZedUp
- constructed from aluminum & plastic for reduced weight



**INNOVATE**

black: INN-B  
silver: INN-S

- modular design
- 10 pockets
- packs in 3 separate parts for reduced shipping size



**DEMONSTRATOR**

DEMONSTRATOR

- 45" h
- stylish acrylic sign holder holds literature in top and bottom pockets
- top frame can be used in landscape configuration only
- acrylic sign holders, brushed silver post and base



**ILLUSION**

black: IL-1-B  
silver: IL-1-S

- fast-folding cantilever rack
- 4 front facing pockets



**VICTORY**

VIC-S

- slim, modular, snap-together design



**10 UP**

black: 10UP-B

- strong & stable
- 10 pockets
- packs flat

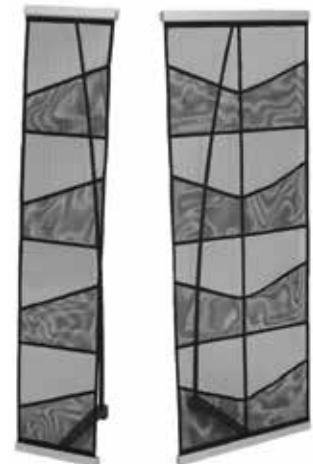

**LR 1 & LR 2**

4 pocket: LR-1  
8 pocket: LR-2

- modular, roll-up mesh design
- holds standard 8.5" w x 11" h literature
- 4 or 8 pocket model
- black with chrome accent



All literature racks come with a five year limited warranty, a carry bag, and are an eco-friendly choice

## SIGN STANDS

Easily display a graphic or message with a versatile and easy-to-assemble sign stand. We offer stands that feature adjustable posts, portrait and landscape sign configurations and more.



### SPARTAN SPARTAN



- 52.25" h
- sleek, sign holder features acrylic pocket to hold 8.5" w x 11" h literature
- silver aluminum alloy post and circular black base
- add second post to hold a larger rigid graphic

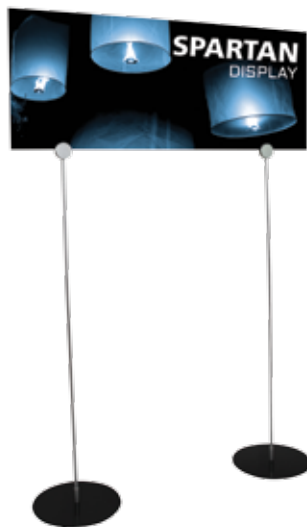

### OBSERVE PRO OBS-LP-SYS

- 48" h
- lightweight, snap-together info center with 12" dia. base
- stylish curved header & adjustable brochure holder
- accepts 8.5" w x 11" h literature & graphic



### ACCLAIM ACCLAIM



- telescopic post offers variable height from 37" - 54.5"
- modern aluminum swiveling sign holder holds rigid 17" w x 11" h graphic
- brushed silver holder, post and square base



### ADVOCATE ADVOCATE



- telescopic post offers variable height from 30.5" - 48"
- versatile aluminum sign holder holds 8.5" w x 11" h literature
- frame can be rotated 360 degrees or any desired angle
- chrome finish holder, post and circular base



### SNAPPER STAND SNP-STAND

- 40" h
- stylish, easy snap-open 11" w x 17" h frame
- frame can be used in portrait and landscape configurations
- silver aluminum sign holder, post and base



### ACCOLADE ACCOLADE



- telescoping post offers variable heights from 33" - 51"
- premium bamboo sign holder holds 8.5" w x 11" h paper
- frame can be used in portrait and landscape configurations
- comes with canvas carry bag



## SIGN STANDS

Easily display a graphic or message with a versatile and easy-to-assemble sign stand. We offer stands that feature adjustable posts, portrait and landscape sign configurations and more.

### OBSERVE DELUXE OBS-DLX

- 74.5" h
- stylish double-sided curved design
- holds two 24" w x 36" h bubble graphics
- recommended printing material: .040"-.125"
- elegant brushed silver
- sturdy steel base with removable and adjustable brochure pockets



### OBSERVE GRAND OBG-B

- 37" h
- sleek info center includes sturdy base & adjustable shelf
- accepts 22" w x 28" h graphic size
- single or double-sided
- holds a 3/16" thick mounted graphic



### TRAPPA POST



- versatile Trappa Posts feature snap sign frames & come in a variety of configurations and sizes
- sturdy aluminum posts and heavy domed steel plate ensure stability
- choice of silver or black snap frames, large or small, landscape, portrait or diagonal
- front loading graphic mechanism makes graphic changes easy
- includes clear protective lenses

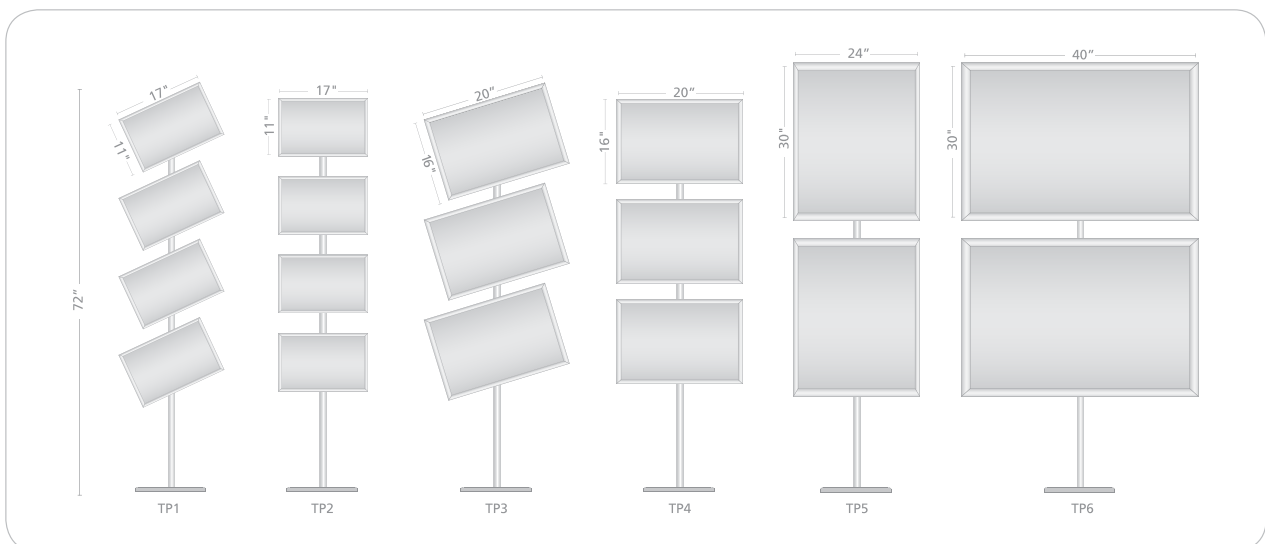

## TOWERS

Maximize your messaging in any lobby, entryway, at any event or tradeshow with a versatile display tower. From backlit to bamboo features, you are sure to find a tower that suits your messaging needs.



### BACKLIT TOWER

- collapsible double-sided free-standing towers, just add the optional lighting kit and turn your tower into a free-standing lightbox!
- 24" or 33" w x 72" h "bubble" panels for maximum visibility
- recommended printing material: .040"-.125"
- your choice of silver or black aluminum edge extrusions
- black thermoformed laminate top & bottom plates



### TRI TOWER TRI-TOWER

**NEW**

- 24" w x 72" h free-standing triangular display tower
- spring-loaded snap edge uprights for quick and easy graphic changes
- black thermoformed laminate top and bottom base, brushed silver aluminum uprights
- includes backer and clear protective lenses for all sides
- literature pocket accessory available



### ACCOLADE TOWER ACCOLADE TOWER

**NEW**

- 24" w x 52" h x 11" d free-standing bamboo display tower
- double-sided
- includes two graphic backers
- allows 1/16" thick graphic panels





Maximize your messaging in any lobby, entryway, at any event or tradeshow with a versatile display tower. From backlit to bamboo features, you are sure to find a tower that suits your messaging needs.

## CUBE TOWER PRISM TOWER

- easy-to-use snap frames featured on all sides
- variety of configurations and sizes available
- choice of silver or black snap frames
- seamlessly display multiple graphics and messages
- front loading graphic mechanism makes graphic changes easy
- frames come with clear protective lenses
- options include wheels or feet
- custom sizes also available



TOP



TOP

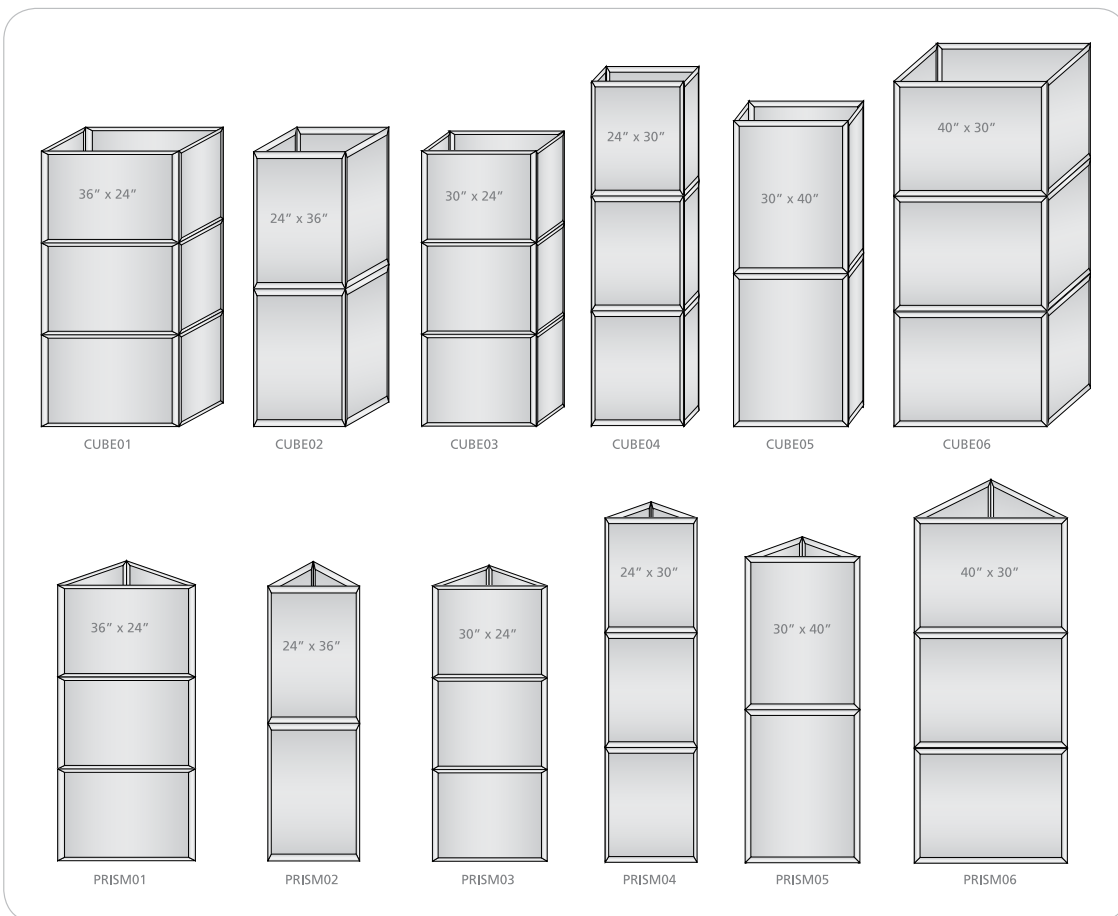

## SNAP FRAME LIGHT BOXES



Snap Frame LED Light Boxes features an edge-lit LED diffuser panel, a thin 1" profile and easy-to-use snap frames. The LED diffuser panel ensures even light distribution and brightness. Silver frames snap open from the front to allow quick and easy graphic changes. No tools are required. Comes standard with clear protective lenses, full assembled and ready to hang. Snap Frame LED Light Boxes are ideal for permanent retail displays, corporate environments, eye-catching tradeshow graphics and more.

### TRAPPA LIGHTBOX



- only 1" thick (single sided only version offered)
- 50,000 hr bulb life
- evenly distributed light
- snap frames allow easy graphic changes
- wall mounting hardware
- power supply with 78" cord

#### AVAILABLE SIZES:

LED-SNAP-01:	16" x 20"
LED-SNAP-02:	22" x 28"
LED-SNAP-03:	24" x 36"
LED-SNAP-04:	30" x 40"
LED-SNAP-05:	36" x 48"



UNLIT

LIT

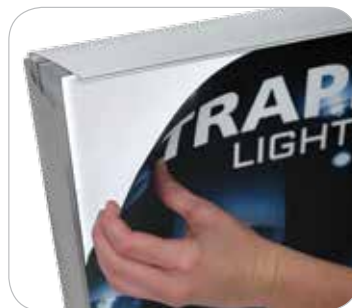

### TRAPPA POSTER FRAME



- black or silver anodized finish w/precision mitered corners
- spring loaded aluminum extrusions mounted to a high-impact polystyrene backer
- trappa frame edges snap open from the front to allow quick and easy graphic changes with no tools required
- available in a wide range of standard sizes & includes a clear anti-glare lens







## DISPLAY ADDITIONS

From miniature retractable banner stands to poster frames, towers, bag dispensers and more. Display accessories and accents are designed to help add the final touches, function and flare to any display or space.

### POSTER SNAPPER



- adjustable hanging clips slide along the top rail to match desired spacing
- hanging clips feature both top opening for clear nylon line mount, and recessed pocket for S-hook suspension
- rails snap open and shut for quick graphic changes
- clean, simple, elegant look
- comes in 4 different standard widths: 24", 30", 36", 48"
- custom cut width available up to 60"



### BREEZE

BREZ-1-S: 8.375" w x 13" h  
BREZ-2-S: 11" w x 17" h



- retractable tabletop stand
- ideal for custom calendars & other promotional banners



### L-MINI



- standard height = 26.875" h
- tabletop tension banner stand
- adhesive rail
- anodized silver finish



### APEX



- double-sided plastic a-frame
- can be printed directly on the plastic for a smooth look
- for indoor or outdoor use



### WEDGE



- combine multiple units for longer and taller displays
- graphic size is variable
- black only
- graphics not included



### AMBASSADOR



- magnetic name badge
- 2.94" w x 1.25" h
- silver finish



### OASIS

- highly portable
- three arm collapsible bag dispenser
- shiny silver finish



### STEP STOOL



- sturdy EZ FOLDZ step stool
- 300 lb capacity
- folds flat for storage & transport
- blue only



## LUMINOSITY™ DISPLAY LIGHTING



Lighting can create a powerful, impactful presence or display. Illumination is an important piece of the puzzle to achieve the mood, style and staging that you desire. A variety of Luminosity™ display lights, lighting kits and solutions to help clients make their projects shine!



### LUMINA 1

black: LUM-1-B  
chrome: LUM-1-C

- low voltage 50 watt spotlight & universal fittings kit
- "goose neck" arm
- mounts horizontally
- LED option available

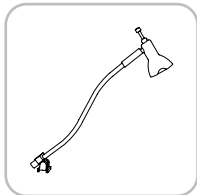

### LUMINA 2

LUM-2-1

- low voltage 50 watt slender spotlight
- mounts to a vertical pole
- brushed stainless steel finish
- LED option available

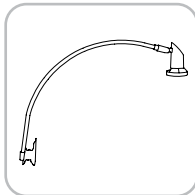

### LUMINA 3

LUM-3

- low voltage 50 watt spotlight, chrome with a black head & universal fittings kit
- telescopic arm
- extends from 7"-22" long
- LED option available

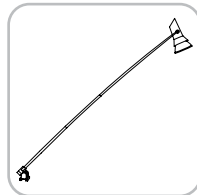

### LUMINA 5

LUM-5

- low voltage 50 watt spotlight & universal fittings kit
- deluxe chrome head
- telescopic arm
- extends from 7"- 22" long
- LED option available

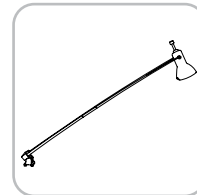

### LUMINA 6

LUM-6

- low voltage, 50 watt spotlight & universal fittings kit
- stylish curved twin arms
- silk black only
- LED option available

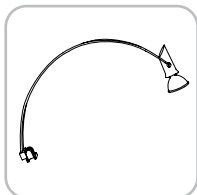

### LUMINA 8

black: LUM-8-B  
silver: LUM-8-C

- 12 volt spotlight with straight arm & adjustable head
- includes 110 volt UL approved transformer, 50 watt bulb & universal fittings kit
- 17" long from end to end
- LED option available

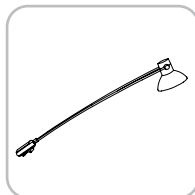

### LUMINA 200

LUM-200-ORL

- 110 volt ETL approved wall washer floodlight with a straight arm & adjustable head
- light includes 120 watt halogen bulb
- 19.5" long from end to end
- silk black finish

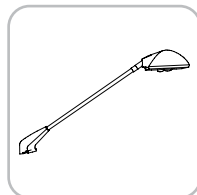

### LUMINA 200 LED

Black: LUM-LED2-ORL-B  
Silver: LUM-LED2-ORL-S

- LED Lumina 200 floodlight
- Uses multi cups chip on board (MCOB) light technology and features a slim profile
- LED rated for 20,000 continuous hours
- 19" long from end to end

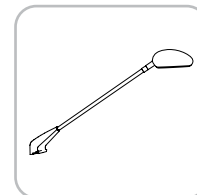

**NEW**



**LUMINA 200 LED**  
LUM-LED-ORL-B  
LUM-LED-ORL-S

- LED version of the Lumina 200 floodlight
- 1400 Ma, 12 VDC
- LED rated for 20,000 continuous hours



**UNIVERSAL LIGHT CLAMP KIT**  
UNI-LT-CLP

- comes standard with the Lumina 1, 3, 4, 5, 6, 8 and allows our lights to fit a majority of banners, truss & panel kits



**SPT CASE**  
SPT-CASE

- EVA semi-rigid lighting case
- foam-lined padded compartments
- holds two Lumina lights & power supply



**LED BULB OPTION**  
LUM-LV-LED-BLB16

- a green solution for Lumina 1, 2, 3, 4, 5, 6, 8
- 50 watt LED bulb



**LUMINA SPARE BULB KIT**  
LUM-BULB

- (2) 50 watt low voltage spare bulbs in a padded, protective EVA formed case

**ILLUMINATE FORMULATE™ FUNNELS, CYLINDERS, TOWERS AND MORE**

**LED FLOOD LIGHT**  
LED-FLOOD

- 85-265 voltage, 42 watt LED Flood light (equivalent to 400 watt halogen)
- projects cool WHITE light
- 7.4" w x 9.44" l x 5.11" d
- angles to 120°
- UL approved



**MINI LED FLOOD LIGHT**  
LED-10W-FLOOD-RGB  
LED-10W-FLOOD-W

- 10 watt LED Flood light
- projects cool WHITE or RGB spectrum light
- remote control provided with RGB version
- each light measures 4.49" w x 3.39" h x 3.98" d
- angles to 120°
- UL approved



**COLOR BLAST ACCENT LIGHTS**

- 85-265 voltage, 13 watt LED blast light
- projects your choice of warm or cool WHITE, and a RGB spectrum flashing pattern
- 7" round x 7" h (when faceplate is flush with base and not angled)
- angles to 60°
- UL approved



**LED-WRM-WHT-BLAST**  
Features a warm white LED light output; good for light-colored and neutral graphic prints. 3,000K



**LED-COOL-WHT-BLAST**  
Features a cool LED light output; good for darker graphic prints. 6,000K



**LED-RGB-BLAST**  
Features multi-pattern flashing RGB LED light output; RGB spectrum cannot be controlled.

## CASES & CRATES

It's critical to protect your tradeshow exhibit investment with a quality constructed transit and shipping case. An extensive selection of exhibit and display cases and crates to choose from that are all made in the USA and are designed to house specific lines of exhibits and displays for maximum portability and protection during shipping.

### OCA2

#### OCA2

- ideal for lights and accessories
- secure straps help to assure case will remain closed during transport
- interior size:  
32"l x 13"h x 4"d
- exterior size:  
34"l x 15"h x 7"d
- weight when empty: 8 lbs



### OCS AND OCL

#### small: OCS

#### large: OCL

- **NEW** premium latches for maximum strength
- built in wheels and easy-to-grip molded handle

#### OCS

- interior size:  
13"l x 15"h x 39"d
- exterior size:  
19"l x 19"h x 45"d
- weight when empty: 18 lbs

#### OCL

- interior size:  
13"l x 15"h x 51"d
- exterior size:  
19"l x 19"h x 57"d
- weight when empty: 20 lbs



### OCB

#### OCB

- this expandable shipping case fits up to three swivel-foot banner stands with bags or one premium stand with bag\*
- also used for Formulate™ Lite displays
- interior size min/max:  
min - 24"l x 12"h x 4"d  
max - 41"l x 12"h x 4"d
- exterior size:  
min - 30.25"l x 14"h x 6"d  
max - 46.75"l x 14"h x 6"d
- weight when empty: 9 lbs
- \*case does not fit Uno, Spring 5, Contender 48 or banners over 39.37" wide



### OCE

#### OCE

- the perfect protective shipping and/or storage case for all Formulate™ exhibit kits, hanging structures and accessory products
- adjustable roto-molded expandable display case
- adjustable lid and easy pin latch
- interior size min/max:  
min - 38"l x 14"h x 11"d  
max - 64"l x 14"h x 11"d
- exterior size min/max:  
min - 40"l x 18"h x 18"d  
max - 66"l x 18"h x 18"d
- weight when empty: 27 lbs
- separate fabric graphic converts the case into a counter



**OCP**  
OCP

- light storage in the lid
- premium latches for maximum strength
- interior size:  
35"l x 21"h x 12"d
- exterior size:  
40"l x 26"h x 16"d
- weight when empty: 31 lbs



**OCP2**  
OCP2

- premium latches for maximum strength
- hinged lid with internal light storage
- robust, roto-molded plastic
- interior size:  
34"l x 22"h x 13"d
- exterior size:  
40"l x 26"h x 18"d
- approximate weight when empty: 32 lbs



**OCP ELITE**  
OCP-ELITE

- lid can be used as a step stool while assembling displays
- access door provides storage when unit is used as a counter
- interior size:  
35"l x 21"h x 14"d
- exterior size:  
39"l x 27"h x 18"d
- weight when empty: 31 lbs



**OC-HOP**  
OC-HOP

- ideal for Hopup backwall displays (fits up to 4x3 hopup)
- built-in handle and wheels for easy transport
- interior size: 34"l x 14"h x 14"d
- exterior size: 38"l x 19"h x 19"d
- weight when empty: 17 lbs



**OCH**  
OCH

- roto-molded case for exhibits, graphics & accessories
- secure reinforced straps help to assure case will remain closed during transport
- strong yet lightweight
- interior size:  
47"l x 23"h x 8"d
- exterior size:  
50"l x 29"h x 12"d
- weight when empty: 22 lbs



**OCH2**  
OCH2

- heavy-duty shipping and storage case
- ideal for Linear hybrid displays
- secure reinforced straps help to assure case will remain closed during transport
- interior size:  
48"l x 24"h x 14"d
- exterior size:  
52"l x 30"h x 14"d
- weight when empty: 30 lbs



All cases come with a one year limited warranty, are an economic & eco-friendly choice, & made in the USA.

**OCHM**  
OCHM

- interlocking surface to enable two cases to be transported together
- maximum case depth = 8" allowing up to 8 flat panels per case
- interior size: 36"l x 23"h x 9"d
- exterior size: 38"l x 28"h x 13"d
- weight when empty: 20 lbs



**OCFM**  
OCFM

- interlocking surface to enable two cases to be transported together
- maximum case depth= 8" allowing up to 8 flat panels per case
- interior size: 27"l x 35"h x 9"d
- exterior size: 49"l x 39"h x 15"d
- weight when empty: 35 lbs



**OCF**  
OCF

- offers the same features and benefits of the OCT in a rectangular shape
- interior size: 47"l x 35"h x 18"d
- exterior size: 51"l x 38"h x 24"d
- weight when empty: 55 lbs



**OCF2**  
OCF2

- molded stackable shipping crate 18" deep
- heavy-duty roller bearing recessed in bridge of case
- holds 18 layers of flat panels in horizontal direction
- interior size: 47"l x 47"h x 18"d
- exterior size: 51"l x 51"h x 24"d
- weight when empty: 70 lbs



**OCM**  
OCM

- black LDPE case designed for LCD monitors
- built in dry erase board to label contents and location
- fits 37" - 47" screens
- includes 3" casters with rubber wheels
- must be shipped freight
- interior size: 45"l x 30"h x 5"d
- exterior size: 56"l x 36"h x 18"d
- weight when empty: 97 lbs



**OCT**  
OCT

- designed to handle national & international exhibit freight shipments
- offers maximum protection for your exhibit materials
- interior size: 47"l x 34"h x 44"d
- exterior size: 50"l x 47"h x 44"d
- weight when empty: 138 lbs



wayfinding signage solutions available at:

[www.SIGNMAKERS-HANDBOOK.com](http://www.SIGNMAKERS-HANDBOOK.com)

featuring a wide range of configurations for a consistent look throughout your building

INFO CENTERS

TRIANGULAR SIGNS

DESK FRAMES

SUSPENDED SIGNS

FREE STANDING PYLONS

WALL-FRAMES

PROJECTING SIGNS

DIRECTORIES



user-friendly, versatile, affordable solutions | front-loading design for easy graphic change

**CONTACT US FOR OPTIONS, SPECS & DIMENSIONS**

AMERICA'S  
**FAVORITE**  
TRADESHOW SUPPLIER

**BROUGHT TO YOU BY:**

[www.exhibitors-handbook.com](http://www.exhibitors-handbook.com)

